

#CP12030 & #CP12030-D Instructions

for 1955-59 Chevrolet Truck & 1953-56 Ford Truck Front Sway Bar

Note:

This kit will work with stock or drop straight axles.

Make sure this kit fits your application before painting or plating. Parts that have been plated, painted or modified may not be returned.

Instructions:

1. Place front of the truck on jackstands under the axle. The front suspension needs to be loaded when installing the sway bar. Remove the front wheels.
2. The sway bar bolts directly to the front of the axle. Using the u-bolts, fit the sway bar to the axle as shown in the diagrams below.
3. Raise the sway bar up so the ends are parallel with the leaf springs.
4. Assemble the end links and mount them through the hole in the sway bar ends and the hole in the frame bracket. Hold them straight up. Go ahead and clamp the brackets to the frame rail. Measure to make sure the brackets are the same height on both sides. Once the brackets are in the correct position, drill the mounting holes and install the hardware provided to bolt the bracket to the frame rail.
5. Make sure all hardware is tight. Do not over tighten the end link bushing bolts.
6. Reinstall the front wheels and place the truck on the ground. Turn the wheels left and right to make sure there is no binding or rubbing.

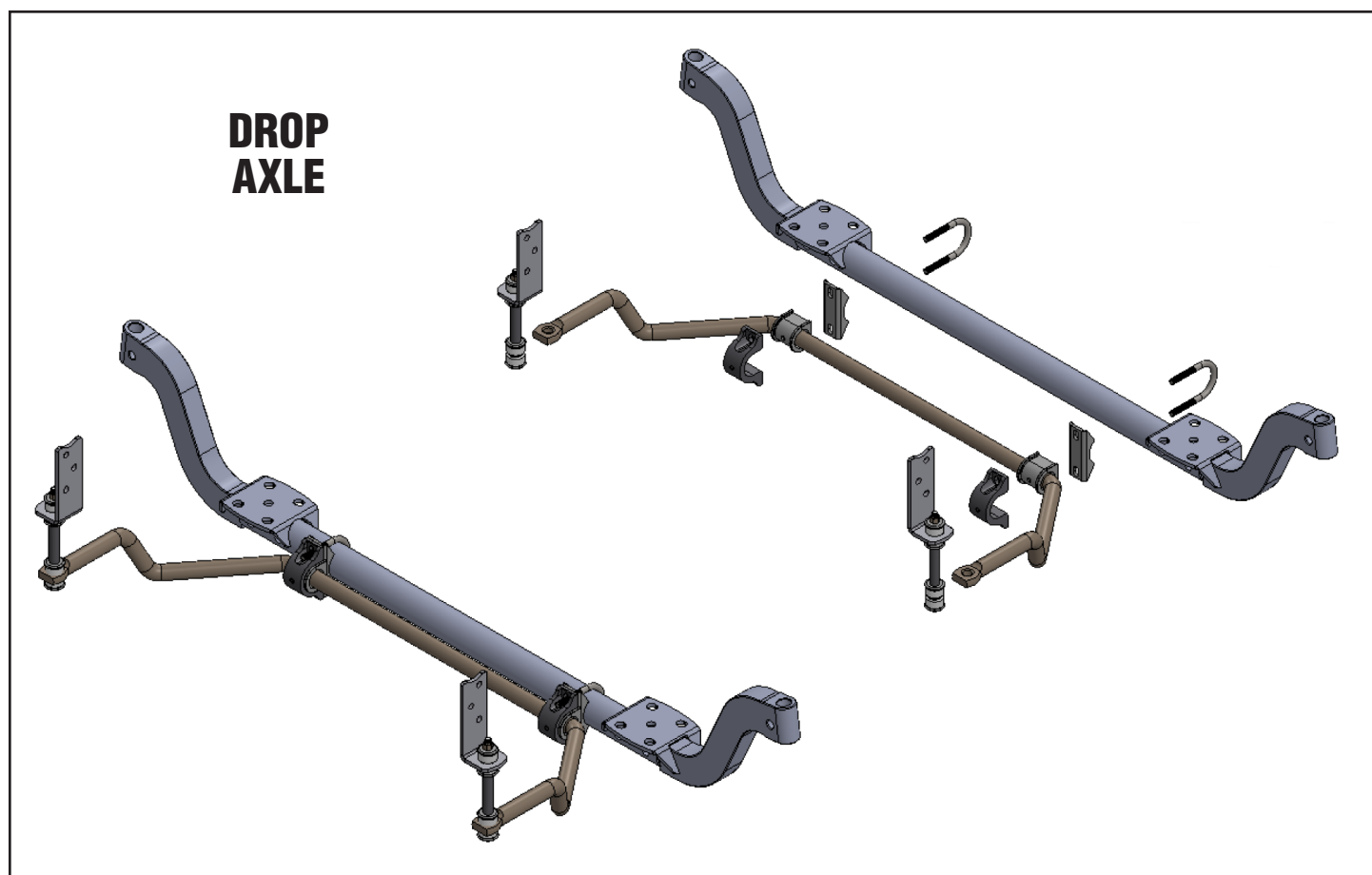

Continued on next page



Steering, Brake & Suspension Specialists

#CP12030 & #CP12030-D Instructions (Continued)

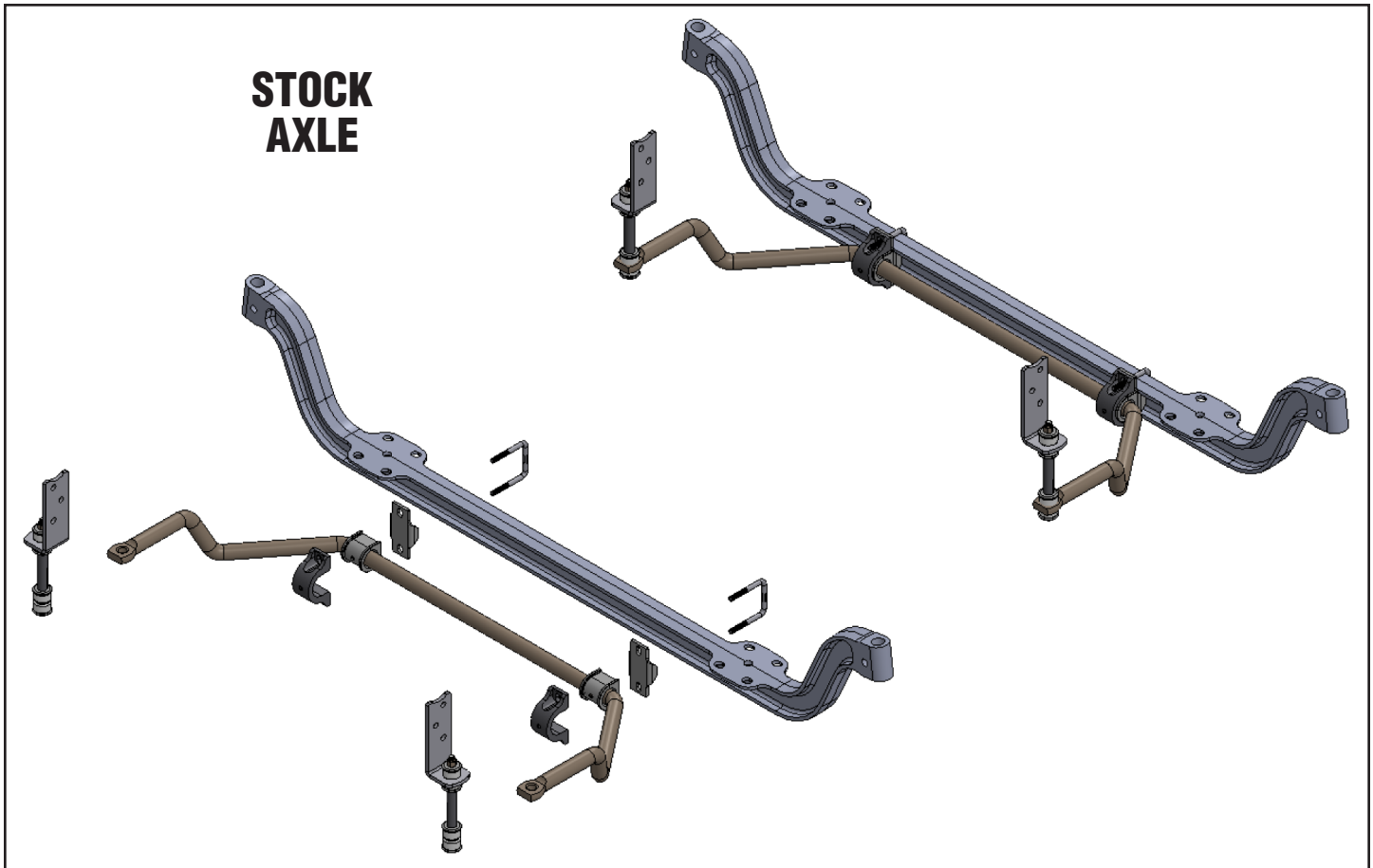

PLEASE NOTE: The installer needs to make sure that nothing can make contact with a brake hose, caliper, or other brake component at any point through the entire range of steering and suspension movement. The installer also needs make sure none of the steering or braking components can become bound or jammed at any time through the range of suspension or steering movement.

© Classic Performance Products, Inc. 2015
All rights reserved. This document may not be reproduced without prior written permission of CPP.

GENERAL TORQUE SPECIFICATIONS:					
1/4"	grade 5	10lb/ft	1/4"	grade 8	14lb/ft
5/16"	grade 5	19lb/ft	5/16"	grade 8	29lb/ft
3/8"	grade 5	33lb/ft	3/8"	grade 8	47lb/ft
7/16"	grade 5	54lb/ft	7/16"	grade 8	78lb/ft
1/2"	grade 5	78lb/ft	1/2"	grade 8	119lb/ft
9/16"	grade 5	114lb/ft	9/16"	grade 8	169lb/ft
5/8"	grade 5	154lb/ft	5/8"	grade 8	230lb/ft

NOTE: With 18" and larger wheels we recommend 1/2" wheel studs. The larger the wheel diameter, the greater the force is on the wheel studs. Please inquire about replacement wheel stud kits available from CPP.