

ASSEMBLY INSTRUCTIONS

FOR

REAR AXLE DISC / DRUM INTERNAL PARKING BRAKE KIT WITH 12.90" DIAMETER VENTED ROTOR (2.66 OFFSET)

SMALL BEARING FORD

PART NUMBER GROUP

140-9216

WARNING

INSTALLATION OF THIS KIT SHOULD **ONLY** BE PERFORMED BY PERSONS EXPERIENCED IN THE INSTALLATION AND PROPER OPERATION OF DISC BRAKE SYSTEMS. IT IS THE RESPONSIBILITY OF THE PERSON INSTALLING ANY BRAKE COMPONENT OR KIT TO DETERMINE THE SUITABILITY OF THE COMPONENT OR KIT FOR THAT PARTICULAR APPLICATION.

RACING EQUIPMENT AND BRAKES MUST BE MAINTAINED AND SHOULD BE CHECKED REGULARLY FOR FATIGUE, DAMAGE AND WEAR.



WARNING

DO NOT OPERATE ANY VEHICLE ON UNTESTED BRAKES!

BEFORE OPERATING VEHICLE, TEST THE BRAKES UNDER CONTROLLED CONDITIONS IN A SAFE AREA. TEST THE SYSTEM IN STATIC CONDITIONS FOR PROPER PEDAL HEIGHT AND THE ABILITY TO HOLD PRESSURE BEFORE ATTEMPTING TO MOVE THE VEHICLE. MAKE SEVERAL STOPS IN A SAFE AREA AT SLOW SPEEDS AND GRADUALLY WORK UP TO NORMAL OPERATING CONDITIONS. **ALWAYS** UTILIZE SAFETY RESTRAINT SYSTEMS AND ALL OTHER REQUIRED SAFETY EQUIPMENT WHILE OPERATING THE VEHICLE.

IMPORTANT

READ THE DISCLAIMER OF WARRANTY INCLUDED IN THE KIT.

WARNING: Some cleaners may stain or remove the finish on brake system components. Test the cleaner on a hidden portion of the component before general use.

Important Notice - Read This First

Before any tear-down or disassembly begins, review the following information:

- Review the wheel clearance diagram (figure 2, page 3) to verify that there is adequate clearance with the wheels you will be using with the installation.
- Rear brake kits are not supplied with hydraulic lines or fittings and may require the purchase of additional lines or fittings to complete the installation. Wilwood offers an extensive listing of brake lines and fitting on our web site: www.wilwood.com.
- Rear brake kits are not supplied with parking brake cables hardware or adapters. Please see the note in the assembly instructions for vendor recommendations to purchase these parts.
- Due to OEM production differences and other variations from vehicle to vehicle, the fastener hardware and other components in this kit may not be suitable for a specific application or vehicle.
- It is the responsibility of the purchaser and installer of this kit to verify suitability / fitment of all components and ensure all fasteners and hardware achieve complete and proper engagement. Improper or inadequate engagement can lead to component failure.

Exploded Assembly Diagram

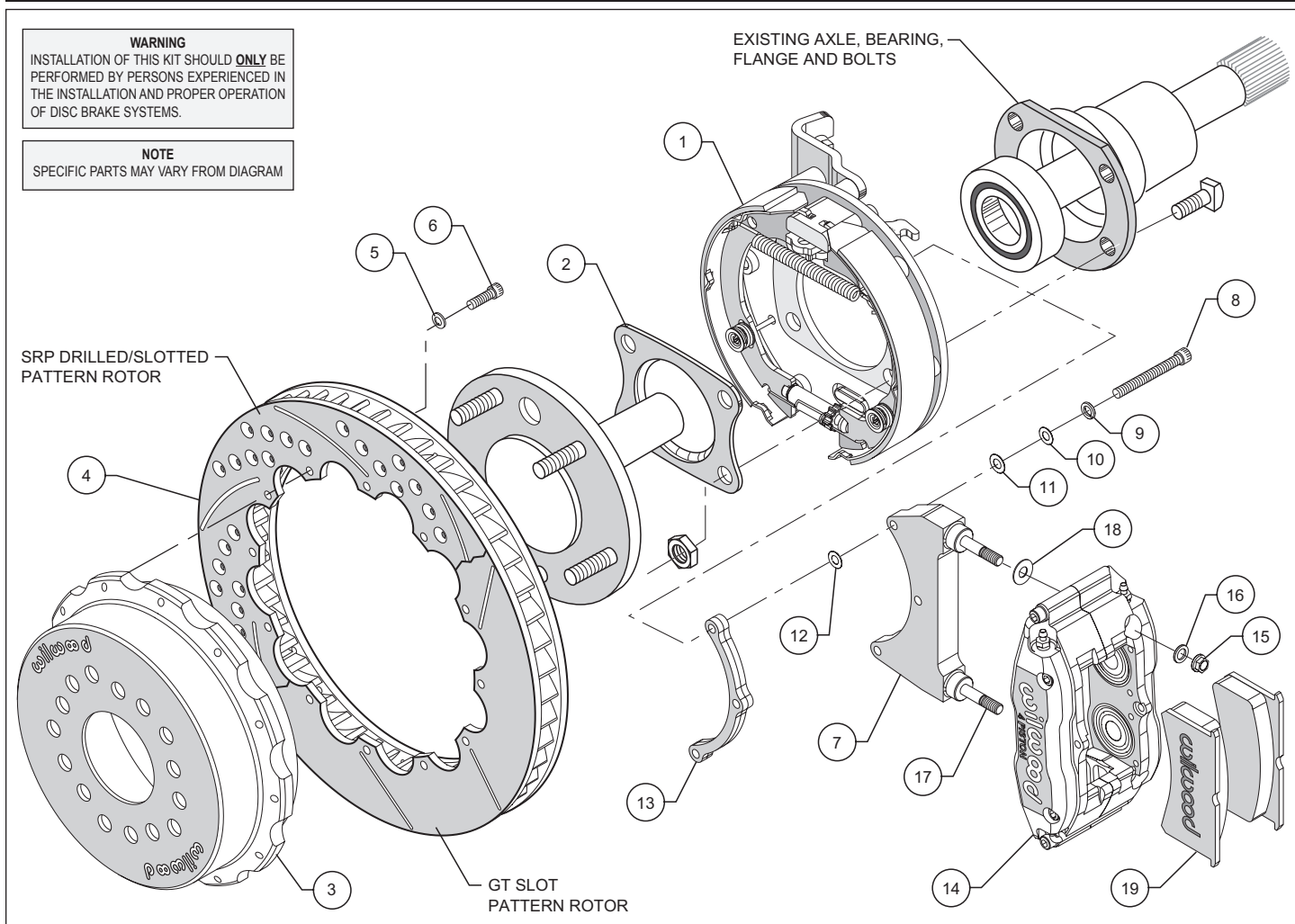

Figure 1. Typical Installation Configuration

Parts List

| ITEM NO. | PART NO. | DESCRIPTION | QTY |
|----------|------------------|--|-----|
| 1 | 249-9778/79 | Bracket Kit (pair, one each, left and right) | 1 |
| 2 | 250-6287 | Retainer, Bearing | 2 |
| 3 | 170-9493 | Hat, 5 x 4.50/4.75/5.00, 1.54 offset, 12 x 8.75 Bolt Circle | 2 |
| 4 | 160-6833/34 | Rotor, GT 1.10" Thk x 12.90" Dia, 12 x 8.75" Bolt Circle, Right & Left | 2 |
| 4A | 160-6835/36 | Rotor, SRP Drilled and Slotted | 2 |
| 5 | 240-2509 | Washer, .250 I.D. x .500 O.D. x .063 Thick | 24 |
| 6 | 230-6738 | Bolt, 1/4-28 x .75 Long, 12 PTCS | 24 |
| 7 | 249-9495/96 | Bracket Caliper Mounting (pair, one each, left and right) | 2 |
| 8 | 230-6317 | Bolt, 5/16-24 x 2.00 Long, SHCS | 6 |
| 9 | 240-0138 | Washer, .312 I.D. x .583 O.D., Split | 6 |
| 10 | 240-0541 | Washer, .329 I.D. x .561 O.D. x .056 Thick | 6 |
| 11 | 240-2663 | Washer, .328 I.D. x .557 O.D. x .094 Thick (Aluminum) | 6 |
| 12 | 240-9609 | Washer, .318 I.D. x .624 O.D. x .015 Thick Shim | 12 |
| 13 | 300-9506 | Spacer, Caliper Bracket | 2 |
| 14 | 120-8062-R/L | Caliper, Superlite 4R | 2 |
| 14A | 120-8062-RP/LP | Caliper, Superlite 4R, Polished | 2 |
| 14B | 120-8062-RRD/LRD | Caliper, Superlite 4R, Red | 2 |
| 15 | 230-9183 | Nut, 3/8-24 Self-Locking Hex Head | 4 |
| 16 | 240-2510 | Washer, .391 I.D. x .625 O.D. x .057 Thick | 4 |
| 17 | 230-9078 | Stud, 3/8-16 x 3/8-24 x 2.50 Long (pre installed in bracket) | 4 |
| 18 | 240-1159 | Washer, .375 I.D. x .875 O.D. x .035 Thick Shim | 16 |
| 19 | 150-8855K | Pad, BP-10 Compound, Axle Set | 1 |

NOTES:

Part Number 250-6287 is included with the bracket kit assembly 249-9778/79

P/N 230-8217 Rotor Bolt Kit, includes part numbers 230-6738 and 240-2509

P/N 250-9632 Caliper Bracket Mounting Bolt Kit, includes P/N's 230-9183, 230-9078, 240-1159, 240-2510 and 249-9495/96

P/N 300-9741 Spacer Kit, includes part numbers 230-6317, 240-0138, 240-0541, 240-2663, 240-9609 and 300-9506

Item 4A is an optional item and included with the "-D" kits. Add "-D" to end of part number when ordering.

Item 14A is an optional item and included with the "-P" kits. Add "-P" to end of part number when ordering.

Item 14B is an optional item and included with the "-RD" kits. Add "-RD" to end of part number when ordering.

General Information

Installation of this kit should **ONLY** be performed by persons experienced in the installation and proper operation of disc brake systems. Before assembling the Wilwood rear axle disc brake kit, double check the following items to ensure a trouble-free installation.

- Make sure this is the correct kit to fit the axle housing flange, not necessarily the rear end make. Many times after market manufacturers put a different make of axle housing flange on the stock rear end housing (see Figure 7). Example; Big Ford rear ends with Olds-Pontiac flanges, therefore, an Olds-Pontiac rear disc brake kit would be the correct kit to order. Also, shock clearance may be a problem. They may have to be modified and/or relocated to clear the Wilwood kit after final assembly.

- Inspect the package contents against the parts list to ensure that all components and hardware are included.

•Verify The Following Measurements Before Assembly.

- Bearing outside diameter.
- Axle housing flange mounting pattern to pattern in bracket.
- Stud pattern on axle flange to stud pattern in hat.
- Dimension from wheel side of axle flange to wheel side of axle housing flange (see Figure 7, lower right hand corner). This dimension is critical to ensure proper alignment of the rotor to the caliper, and should match offset given in the kit description.
- Verify that the wheel axle stud size is 0.50" diameter. The Wilwood hats utilized in these kits are drilled for 0.50" diameter wheel studs.
- Maximum axle flange diameter must be no larger than 6.11" w/.050" x 45° chamfer (see Figure 3).

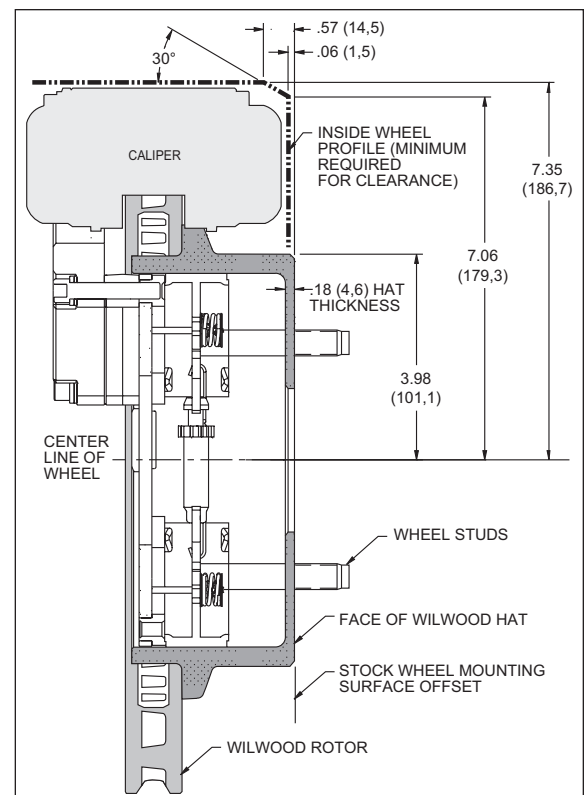

Figure 2. Wheel Clearance Diagram

Disassembly and Assembly Instructions

Disassembly Instructions

- Disassemble the original equipment rear brakes:

Raise the rear wheels off the ground and support the rear suspension according to the vehicles manufacturer's instructions.

Completely disassemble the stock brake system down to the bare axle. Dependent on the type of retainer supplied in the kit, the following steps must be performed.

A. **Full Circle Retainers** require the utilization of a qualified machine shop to press off the axle bearing and OEM retainer. Then have machine shop install new retainer (2), supplied with bracket kit with lip facing toward bearing, reference Figures 1, 4 and 5 (we suggest that you install a new bearing at this time, not supplied with kit).

B. **"U" Retainers** require the removal of the OEM retainer by cutting or grinding a notch in the retainer to facilitate removal. Once OEM retainer is removed, install new retainer (2) supplied with bracket kit with the "U" opening facing up and the lip facing toward bearing, reference Figures 1, 4 and 5.

- Degrease and remove any dings and burrs on housing flange as well as axle flange which may interfere with brake assembly.

Assembly Instructions (numbers in parenthesis refer to the parts list/diagram on the preceding pages): **CAUTION:** All mounting bolts must fully engage insert nuts. Be sure to check that all bolts are either flush or protruding through flanged side of insert nut after shimming.

•Slide the bracket kit assembly (1) onto the housing flange and then insert the axle assembly through the center hole of the bracket kit assembly (1). Align the bearing retainer (2) with the four holes inside the bracket assembly (1) and secure using the stock Original Equipment Manufacturer (OEM) bolts and nuts. Stock OEM hex nuts that retain the bracket kit assembly (1) and retainer (2) should be on the wheel side of the bracket. Apply red *Loctite*® 271 to the stock OEM bolt threads and torque to OEM specifications. Make sure the bracket kit assembly (1) brake pads are **FACING OUTWARD TOWARDS THE WHEEL**.

•With the larger I.D. side of the rotor (4) facing away from the hat (3), bolt rotor (4) to hat (3) through the backside of the rotor using washers (5) and bolts (6). Torque bolts (6) in an alternating sequence to 103 **in-lb**. Safety wire bolts (6) using standard 0.032 inch diameter stainless steel safety wire as shown in Figure 6. Please refer to Wilwood's data sheet DS-386 (available at www.wilwood.org/ds386.pdf) for complete safety wire installation instructions.

•Align the correct hole pattern in the hat (3) with the stud pattern on the axle flange. **NOTE:** Some OEM and aftermarket axles come with stud sizes larger than 0.50" diameter. Verify stud size and have a qualified machine shop drill the hats to the correct size, if necessary. Slide the hat/rotor assembly (3 and 4) over the wheel studs covering the bracket kit assembly (1) and against the axle flange face. Check to be sure the hat seats squarely against the hub. Install a couple of lug nuts (finger tighten) to keep the rotor/hat assembly in place while continuing with the installation.

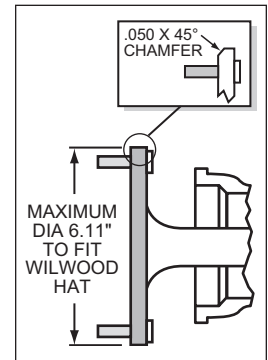

Figure 3. Axle Flange Maximum Dimension

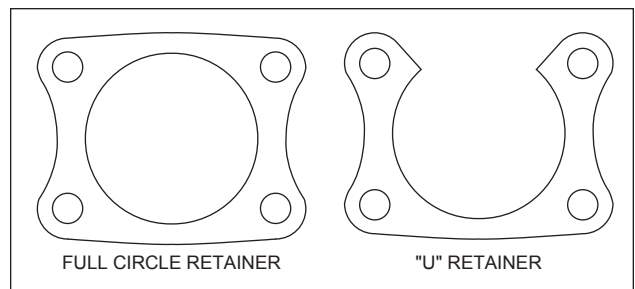

Figure 4. Retainer Styles

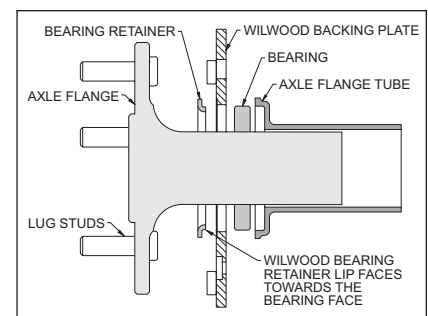

Figure 5. Retainer / Axle Diagram

Assembly Instructions (Continued)

•**NOTE:** Please reference the caution statement at the beginning of the assembly instructions. The caliper mounting bracket assembly (7) should be installed first with clean, dry threads on the mounting bolts (8). Install the bracket from the rear side of the bracket kit assembly (1) by sliding bolt (8) through lock washer (9), flat washers (10 and 11) bracket (7), shim washer (12) and finally through the spacer (13), see Figure 1. **NOTE:** End of bolt should not exceed inside face of insert. The bracket must tighten squarely against the back side of the bracket kit assembly (1). Inspect for interference from casting irregularities, machining ridges, burrs, etc. Use one thin shim (12) between the bracket (7) and spacer (13) during initial trial fitting.

• Install one washer (18) over each pre-installed stud (17) on the radial mount bracket (7). Slide the caliper (14) in place over the studs and rotor, then install the washer (16) and lock nut (15) to hold the caliper in place. The caliper bleed screws should be pointing up. Snug the lock nuts (15) and check that the rotor (4) is centered in the caliper (14). Add or subtract .015" shims (12) as necessary between the caliper mounting bracket (7) and the spacer (13) to center the caliper (9).

• Remove the caliper center bridge pad retainer bolt, nut, and tube from the caliper. Slide the brake pads (19) into place. They should install easily without interference. Check that the outside radius of the brake pad is aligned with the outside diameter radius of the rotor face. Add or subtract shims (18) between the caliper (14) and mount bracket (7) to gain the proper alignment. Reinstall the center bridge pad retainer tube, bolt, and locknut. The locknut should be snug without play in the bolt or tube. Be cautious not to over tighten.

• Adjust the parking brake shoes outward (using a drum shoe adjustment tool available at your local auto parts store) while spinning the hat (3) until a slight drag is felt against the hat/drum. Remove the lug nuts that were holding the hat/rotor in place. Install the wheel and lug nuts. Check to see that the wheel rotates freely without interference.

• Once all clearances have been checked, remove the wheel, caliper, hat/rotor from the bracket kit assembly (1). Secure the caliper mounting bracket (7) to the bracket kit assembly (1) using red *Loctite*® 271. Torque bolts (8) to 180 **in-lb**. Reinstall the hat/rotor assembly and again use lug nuts to hold it in place. Lubricate caliper mounting studs and nuts with lightweight oil, reinstall the caliper, torque the caliper nuts (15) to 30-35 **ft-lb**.

•**NOTE:** Clevis and cable kits which attach to the parking brake assembly are not included in the Wilwood parking brake kit. A universal cable kit, Wilwood part number 330-9371 is available. Lokar Performance Products and their distributors carry a complete line of cable kits and accessories that will fit this system. They can be reached at 865 / 966-2269.

•**NOTE:** OEM rubber brake hoses will not adapt to Wilwood calipers and should not be used. The caliper inlet fitting is a 1/8-27 NPT. Use steel adapter fittings at the caliper, either straight, 45 or 90 degree and enough steel braided line to allow for full suspension travel. **Carefully route lines to prevent contact with moving suspension, brake, or wheel components.** Periodically check hose and components for any wear. Wilwood brake and hose kits are designed for use in many different vehicle applications and it is the installer's responsibility to properly route and ensure adequate clearance and retention for brake hose components.

• Repeat this entire procedure for the other wheel.

• Bleed the brake system. Reference the general information and recommendations on the last page for proper bleeding instructions.

• Remove the lug nuts that were used to hold the hat/rotor assembly in place during caliper installation. Install the wheel and lug nuts, torque to OEM specifications.

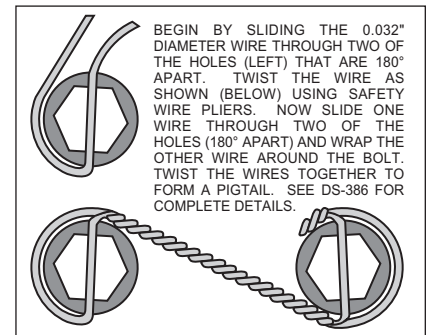

Figure 6. Safety Wire Diagram

Assembly Instructions (Continued)

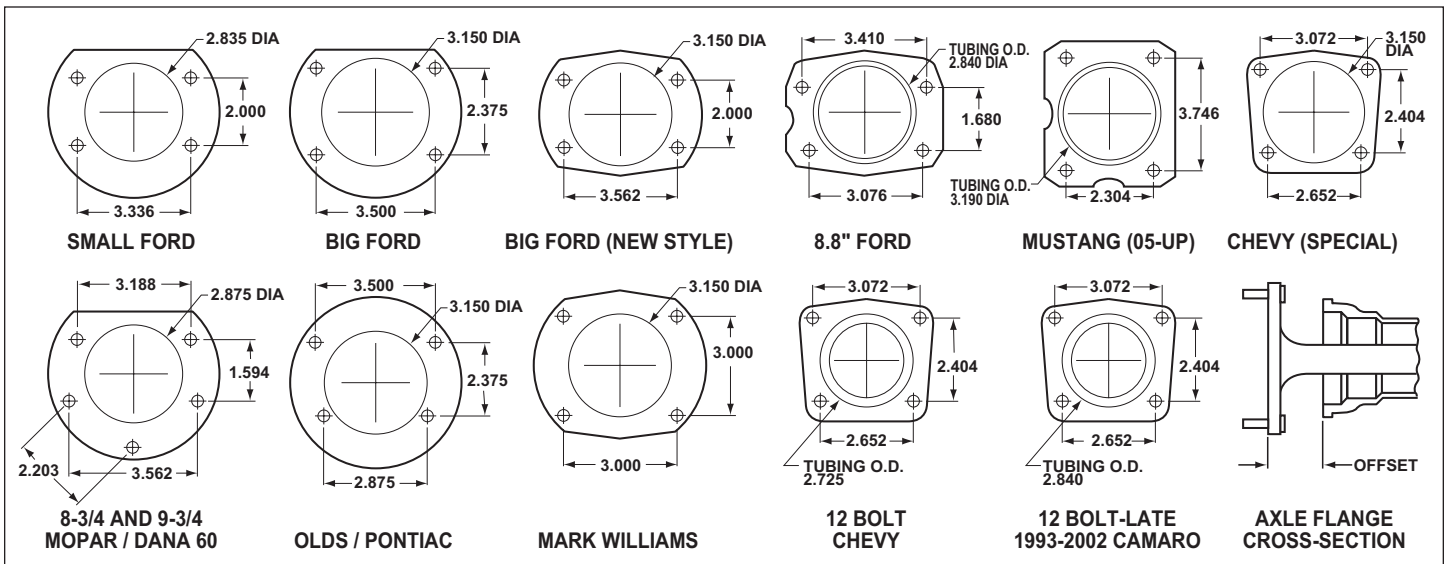

Figure 7. Rear Housing Flange Chart and Axle Flange / Offset Cross-Section

Additional Information and Recommendations

•**NOTE:** With the installation of after market disc brakes, the wheel track may change depending on the application. Check your wheel offset before final assembly.

•Please read the following concerning balancing the brake bias on 4 wheel disc vehicles.

This brake kit can be operated using the stock OEM master cylinder and proportioning system. However, as with most suspension and tire modifications (from OEM specifications), changing the brakes may alter the front to rear brake bias. Rear brakes should not lock up before the front. Brake system evaluation and tests should be performed by persons experienced in the installation and proper operation of brake systems. Evaluation and tests should be performed under controlled conditions. Start by making several stops from low speeds then gradually work up to higher speeds. Always utilize safety restraint systems while operating vehicle.

Use a Wilwood adjustable proportioning valve if necessary to achieve proper brake balance, or use a Wilwood brake pedal/balance bar assembly with dual master cylinders (requires custom mounting as used in fabricated chassis race cars). A balance bar brake system permits incremental front to rear brake pressure adjustments.

Additional Information and Recommendations (Continued)

- For optimum performance, fill and bleed the new system with Wilwood Hi-Temp^o 570 grade fluid or EXP 600 Plus. For severe braking or sustained high heat operation, use Wilwood EXP 600 Plus Racing Brake Fluid. Used fluid must be completely flushed from the system to prevent contamination. **NOTE:** Silicone DOT 5 brake fluid is **NOT** recommended.
- To properly bleed the brake system, begin with the caliper farthest from the master cylinder. Bleed the outboard bleed screw first, then the inboard. Repeat the procedure until all calipers in the system are bled, ending with the caliper closest to the master cylinder. If the caliper is fitted with bleed screws on four corners, make sure the bottom bleed screws are tight. Only bleed from the top bleed screws. **NOTE:** When using a new master cylinder, it is important to bench bleed the master cylinder first.
- If the master cylinder is mounted lower than the disc brake calipers, some fluid flowback to the master cylinder reservoir may occur, creating a vacuum effect that retracts the caliper pistons into the housing. This will cause the pedal to go to the floor on the first stroke until it has "pumped up" and moved all the pistons out against the pad again. A Wilwood in-line 2 lb. Residual Pressure Valve installed near the master cylinder will stop the fluid flowback and keep the pedal firm and responsive.
- Test the brake pedal. It should be firm, not spongy, and stop at least 1 inch from the floor under heavy load.
 - If the brake pedal is spongy, bleed the system again.
 - If the brake pedal is initially firm, but then sinks to the floor, check the system for leaks. Correct the leaks (if applicable) and then bleed the system again.
 - If the brake pedal goes to the floor and continued bleeding of the system does not correct the problem, either air may be trapped in the system, or a master cylinder with increased capacity (larger bore diameter) may be required. Wilwood offers various lightweight master cylinders with large fluid displacement capacities (custom fabricated mounting may be required).

PAD BEDDING PROCEDURE:

- Pump brakes at low speed to assure proper operation. On the race track, or other safe location, make a series of hard stops until some brake fade is experienced. Allow brakes to cool while driving at moderate speed to avoid use of the brakes. This process will properly burnish the brake pads, offering maximum performance.

Associated Components

| PART NO. | DESCRIPTION |
|-----------------|---|
| 260-1874 | Wilwood Residual Pressure Valve (2 lb for disc brakes) |
| 260-1876 | Wilwood Residual Pressure Valve (10 lb for drum brakes) |
| 260-8419 | Wilwood Proportioning Valve |
| 290-0632 | Wilwood Racing Brake Fluid (Hi-Temp ^o 570) (12 oz) |
| 290-6209 | Wilwood Racing Brake Fluid (EXP 600 Plus) (16.9 oz) |
| 340-1285 | Wilwood Floor Mount Brake Pedal (with balance bar) |
| 340-1287 | Wilwood Swing Mount Brake Pedal (with balance bar) |
| 260-6764 | Wilwood 3/4 inch High Volume Aluminum Master Cylinder |
| 260-6765 | Wilwood 7/8 inch High Volume Aluminum Master Cylinder |
| 260-6766 | Wilwood 1 inch High Volume Aluminum Master Cylinder |
| 260-4893 | 1-1/16 inch Tandem Master Cylinder (aluminum housing) |
| 250-2406 | Mounting Bracket Kit (tandem master cylinder) |
| 260-8555 | Wilwood 1 inch Aluminum Tandem Chamber Master Cylinder |
| 260-8556 | Wilwood 1-1/8 inch Aluminum Tandem Chamber Master Cylinder |
| 350-2038 | 1971 - 1973 Pinto Rack and Pinion (new, not rebuilt) |
| 270-2016 | Quick Release Steering Hub (3/4 inch shaft) |
| 270-2017 | Quick Release Steering Hub (5/8 inch shaft) |
| 220-7056 | Flexline Kit, Universal, 14 Inch, Domestic |
| 220-7699 | Flexline Kit, Universal, 16 Inch, Domestic |
| 220-8307 | Flexline Kit, Universal, 18 Inch, Domestic |
| 330-9371 | Cable Kit, Parking Brake, Universal |

Bolt Torque Specifications

| BOLT SIZE | TORQUE |
|------------------|---------------|
| 1/4-20 | 85 in-lb |
| 1/4-28 | 103 in-lb |
| 5/16-18 | 180 in-lb |
| 5/16-24 | 198 in-lb |
| 3/8-16 | 22 ft-lb |
| 3/8-24 | 30 ft-lb |
| 7/16-14 | 42 ft-lb |
| 7/16-20 | 47 ft-lb |
| 1/2-13 | 65 ft-lb |
| 1/2-20 | 77 ft-lb |
| 9/16-12 | 95 ft-lb |
| 9/16-18 | 105 ft-lb |
| 5/8-11 | 110 ft-lb |
| 5/8-18 | 120 ft-lb |

NOTE: This bolt torque specification list is for use with specific grades of bolts as supplied in the particular Wilwood kit and is not intended as a guide for any other application.