



Steering, Brake & Suspension Specialists

#M2WBK-5 - Installation Instructions

Mustang II Disc Brake Kit with 5x5 lug pattern

Parts List:

2 ea	Caliper Bracket	2 ea	Spindle Nut
2 ea	Upper Anchor	2 ea	Nut Cage
2 ea	Lower Spacer	2 ea	Cotter Pin
2 ea	Caliper Assembly	2 ea	Bearing Cap
2 ea	Caliper Hose	2 ea	Brake Hose
2 ea	Hub Assembly	2 ea	7/16-14x2 Bolt
2 ea	Brake Rotor	2 ea	7/16 Flat Washer
2 ea	Grease Seal	2 ea	7/16 Lock Washer
2 ea	Inner Bearing	2 ea	1/2-20x2.5 Bolt
2 ea	Outer Bearing	2 ea	1/2 Flat Washer
2 ea	Spindle Washer	4 ea	1/2 Lock Washer

Instructions:

- Using the 1/2-20x2-1/2" bolt and a 1/2" lock washer, loosely attach the upper anchor to the upper brake boss on the spindle.
- Using the 1/2-20 nut, 1/2" flat washer and 1/2" lock washer loosely attach the caliper bracket to the upper anchor. The flat portion of the caliper bracket should be near the flat portion of the upper anchor.
- Using the 7/16-14x2" bolt and spacer, attach the lower portion of the caliper bracket to the lower brake boss on the spindle. Tighten the caliper bracket and anchor hardware. See the diagram for caliper and bracket mounting details.
- Pack the wheel bearings with grease. Install the inner bearings and grease seal into the hub. Slide the hub assembly over the axle pin. Install the outer wheel bearing, washer and spindle nut. Adjust the wheel bearings as follows:

a. Tighten the nut only slightly (no more than 12lb/ft.) spin the hub in a forward direction to ensure the bearings are fully seated.

b. Check that the spindle nut is still tight. If it is not, repeat step a.

c. Loosen the spindle nut until it is just loose.

d. Hand tighten the spindle nut, install the nut cage, and install the cotter pin. Do not use a wrench! If necessary loosen the nut to the first position the cotter pin can be installed into.

5. Slide the rotor over the wheel studs and hub assembly.

6. Install the caliper assemblies. The bleed screws will be towards the top. Torque the caliper mounting bolts to 35 lbs/ft.

7. Check that the rotor can turn freely and that the brakes do not drag. Install the spindle dust caps.

Upper anchor goes thru the hole in the top of the bracket; 1/2" nut secures the bracket to the anchor

1/2" bolt goes thru the top of the spindle and into the upper anchor

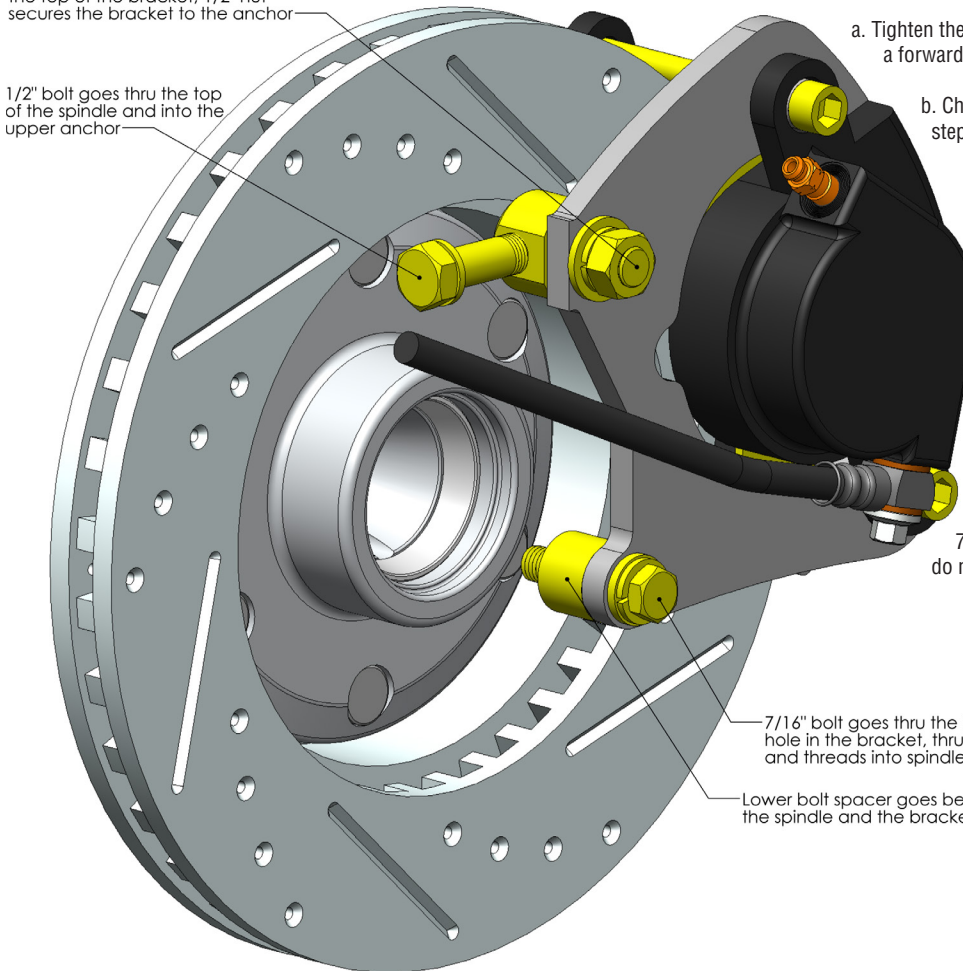

7/16" bolt goes thru the bottom bolt hole in the bracket, thru the spacer, and threads into spindle

Lower bolt spacer goes between the spindle and the bracket

PLEASE NOTE: The installer needs to make sure that nothing can make contact with a brake hose, caliper, or other brake component at any point through the entire range of steering and suspension movement. The installer also needs make sure none of the steering or braking components can become bound or jammed at any time through the range of suspension or steering movement.

© Classic Performance Products, Inc. 2015
All rights reserved. This document may not be reproduced without prior written permission of CPP.

GENERAL TORQUE SPECIFICATIONS:

1/4"	grade 5	10lb/ft	1/4"	grade 8	14lb/ft
5/16"	grade 5	19lb/ft	5/16"	grade 8	29lb/ft
3/8"	grade 5	33lb/ft	3/8"	grade 8	47lb/ft
7/16"	grade 5	54lb/ft	7/16"	grade 8	78lb/ft
1/2"	grade 5	78lb/ft	1/2"	grade 8	119lb/ft
9/16"	grade 5	114lb/ft	9/16"	grade 8	169lb/ft
5/8"	grade 5	154lb/ft	5/8"	grade 8	230lb/ft

NOTE: With 18" and larger wheels we recommend 1/2" wheel studs. The larger the wheel diameter, the greater the force is on the wheel studs. Please inquire about replacement wheel stud kits available from CPP.