

#LS1-K125 Installation Instructions for Original Position LS V8 Engine Mount Adapter

Parts List:

2 ea	Engine Mount Adapter
2 ea	10mm Counter Sink Bolt
4 ea	3/8 Hex Head Bolt
4 ea	3/8 lock Washer
4 ea	3/8 Nut
4 ea	10mm Socket Cap Screw
4 ea	10mm Lock Washer
8 ea	Flat Washer



Instructions:

1. Insert 2 of the 3/8" hex head bolts into each of the adapter brackets so that the head of the bolts are on the opposite side of the counter sink hole.
2. Attach the adapter brackets to the engine. Use the counter sink bolt in the counter sink hole above the long slot, and in the rear most hole use a 10mm socket head cap screw (allen bolt), 10mm lock washer and a flat washer. Tighten both of the bolts.
3. Install the engine mounts to the adapter brackets. The upper 2 bolt holes will fit over the 2 3/8 hex bolts that are already in the bracket. In the lower bolt use a 10mm socket head cap screw (allen bolt), lock washer, and flat washer. This 10mm bolt will go thru both the mount and the adapter bracket. Using the 3/8" nuts, lock washers, and flat washers on the 3/8" hex head bolts, tighten the mount to the adapter.

Note:

Due to variations between different manufacturers' engine mounts, some modifications may be necessary:

If the bump on the back side of the mount interferes with the adapter, you may need to remove a portion of the bump; a grinder works well for this.

Some mounts utilize a steel backing plate. In this case, the new adapter will act as the backing plate.





Steering, Brake & Suspension Specialists

LS1-KS
Stock Position

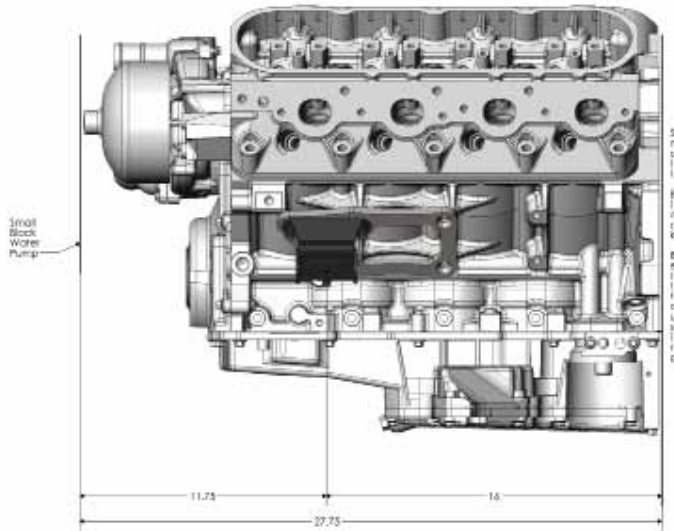

LS1-K125
1-1/4" Forward

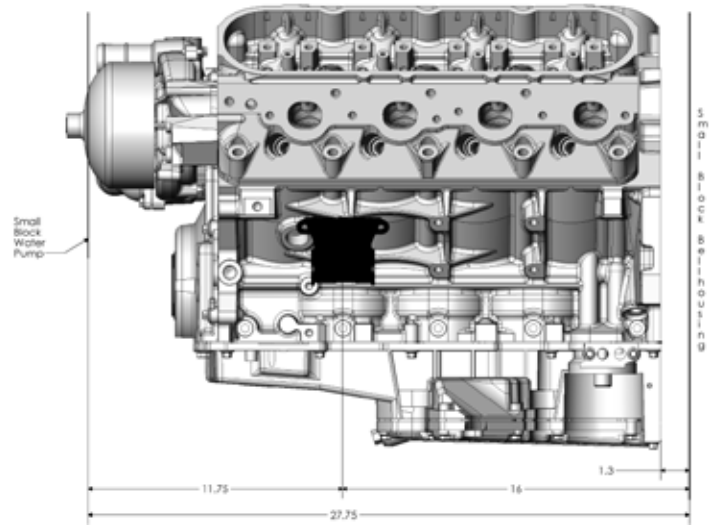

LS1-K3
3" Forward

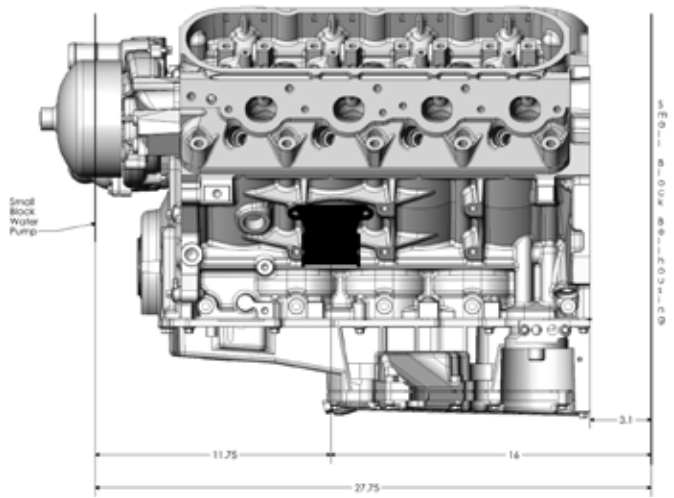

LS1-K
4" Forward

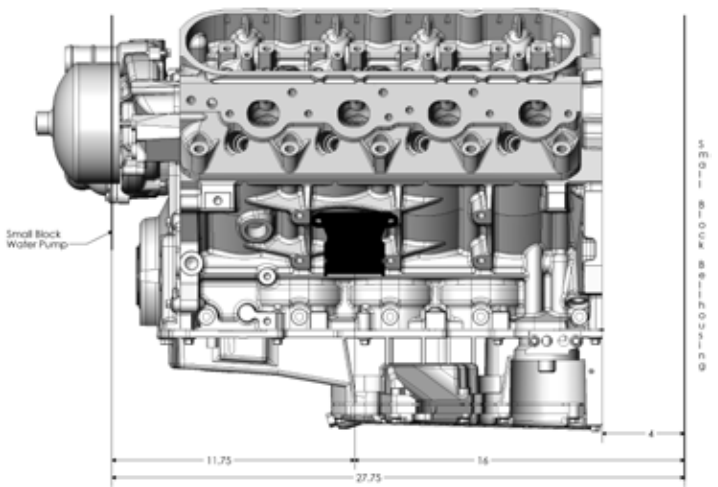

LS1-K125
5-3/4" Forward

