

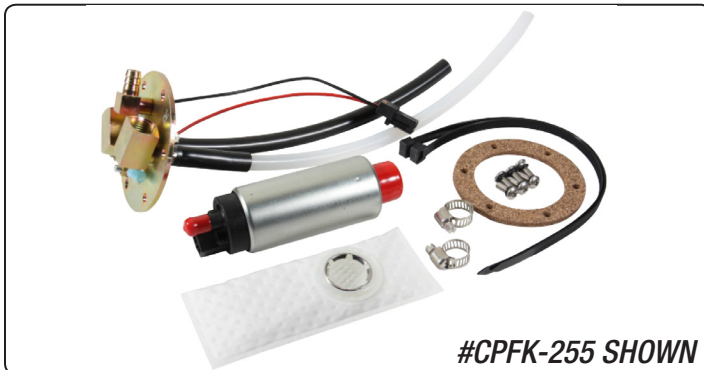

Steering, Brake & Suspension Specialists

Small In-Tank Fuel Pump Assembly & Installation Instructions

For #FK-F1 / #CPFK-255 / #CPFK-340



#CPFK-255 SHOWN

Parts List (#FK-F1):			#CPFK- Kits Also Include:		
1 ea	Pre-Assembled Fuel Pump Housing Assembly w/ Fittings & Supply/Return Hoses	6 ea		Machine Screws	
1 ea	Housing Assembly Gasket	2 ea		Zip Ties	
		2 ea		Hose Clamps	
		1 ea	Filter Sock	1 ea	Fuel Pump (255 LH or 340 LH)

Notes:

- Small in-tank install kit works with most submersible/in-tank fuel pumps.
- Fuel pumps with 5/16" hose barbs need to be sleeved for 3/8" hose

Instructions:

1. Measure from the bottom of the tank up to the top mounting surface where the fuel pump will be installed (D). If the bottom of the fuel tank has ribs or an uneven surface measure from the highest point on the bottom, this will give you the shortest distance to the top of the tank. The final assembled length of the fuel pump module will need to be this distance top to bottom. (FIG. A)

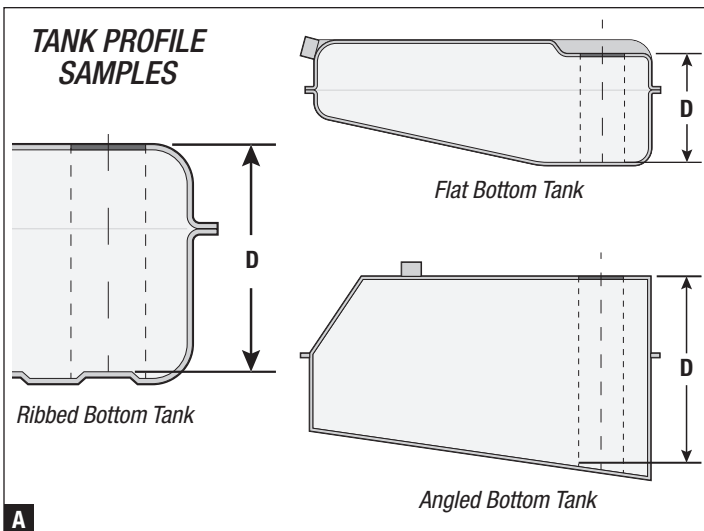

CAUTION: Use proper fire and fuel safety procedures when handling fuel system or related items.

2. Remove the caps or plugs from the fuel pump.
3. Attach the filter sock to the fuel pump. (FIG. B)



4. Lay the fuel pump housing assembly on a clean work surface, like a table top. Position the pump alongside the fuel hose on the fuel pump housing. (FIG. C) The bottom of the filter sock needs to be set to the same distance you measured from the bottom of the tank up to the mounting surface (Step 1). Mark the black supply hose at the right distance to be installed on to the pump. Mark the white return hose about 1/2" above the filter sock.

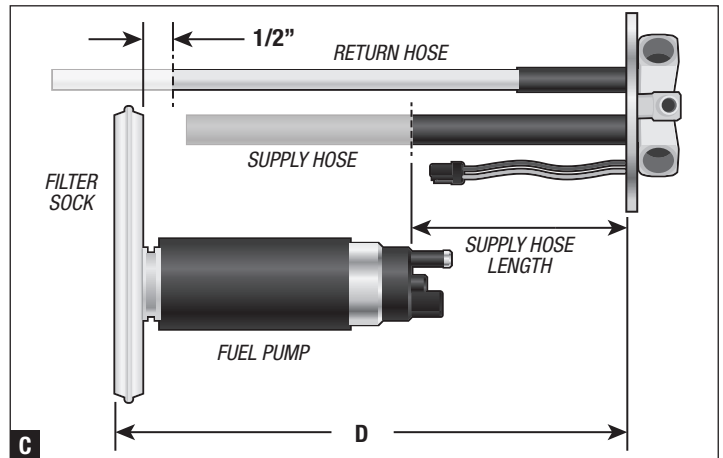

5. Cut the hoses where you marked them. (FIG. C)
6. Connect the electrical connector on to the fuel pump. Ensure the connector is completely installed. It should lock into place with a click.
7. Loosely put the hose clamp over the supply hose.
8. Insert the fuel pump barb into the supply hose. (If the fuel pump has 5/16" hose barb, use a short piece of the white return hose to shim the barb for a 3/8" hose. Cut 1" of the return hose. Heat the hose and install it over the 5/16" hose barb. - FIG. D1-D2)
9. Double check the fuel pump module will fit into the tank without bottoming out the filter sock against the bottom of the tank. Adjust the length of the pump module as needed.
10. Tighten the hose clamp securing the supply hose onto the pump.
11. Install the pump sleeve over the pump body.
12. Using the tie wraps, secure the pump to the return hose.
13. Double check that all of the hose clamps are tight, the wires are routed so they won't get pinched, and the wire connector is locked on the pump.
14. Place the gasket or O-ring onto the tank and install the pump module in the tank.
15. Tighten the pump module onto the tank.
16. Using ring connectors wire the pump module to the vehicle.
17. Connect the supply, return, and vent lines to the pump module. The supply and return ports are 1/4" NPT. Use Teflon tape on the fittings before they are installed. The vent connection is a 3/8" hose barb.
18. Check for leaks before installing tank.

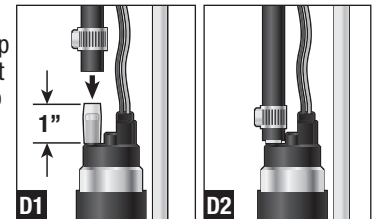

© Classic Performance Products, Inc. 2018 All rights reserved.
This document may not be reproduced without prior authorization or written permission of CPP.