



Steering, Brake & Suspension Specialists

# Column Shift Linkage (for GM Trans excluding Powerglide) Instruction Sheet - #CPTSL

**Note:** Make sure the parking brake is set or the wheels are blocked to prevent accidental movement of the vehicle while installing the shift linkage.

**1.** This is a universal shift linkage kit and is designed to be cut to fit individual applications. Keep in mind header and brake pedal clearances.

**2.** Remove all the factory linkage from the transmission selector shaft and column. Place the transmission in park by rotating the selector shaft clockwise. Put the column shifter in the park position.



**3.** Install the splined bushing onto the transmission selector shaft, make sure the flats on the splined bushing slide over the flats on the transmission selector shaft. The kit also includes one 10mm metric nut and one standard 3/8-16 nut. Use the proper nut for your application. Tighten the splined bushing onto the transmission selector shaft (fig. 1).



**4.** Install the aluminum arm over the splined bushing while in the 8 o'clock position (park). It may be necessary to reposition the aluminum arm per application (fig. 2).

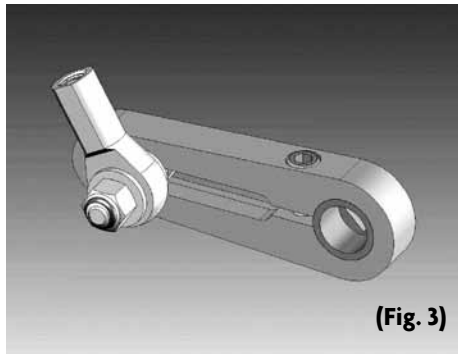

**5.** Positioning of the swivel rod end mounting bolt into the aluminum arm slot will be dependent upon the column distance between gears (fig. 3).



Bolt the swivel rod end onto the column with the washers and spacers as shown in figure. 4.

**6.** Fit the stainless rod (cut and or bend if necessary per your application), starting at the column rod end to the transmission rod end. Adjust the length of the shift rod by cutting it with a hacksaw or cut off wheel. Insert the shift rod into the adjustable hex connector and tighten the set screws. Only tighten enough to mark the rod. Make sure the column will shift into all gears and click firmly into park. After final adjustment, remove the shift rod and grind a small flat spot on the marked rod. When installing the set screw for the final time, its best to use thread locker on the threads.