



Steering, Brake & Suspension Specialists

#CPLS1-K Installation Instructions

for LS1 V8 Engine Mount Adapter

Parts List:

2 ea.	Engine Mount Adapter
2 ea.	Engine Mount
10 ea.	3/8 Flat Washer
6 ea.	M10x1.5x30 Cap Screw
6 ea.	3/8 Lock Washer
4 ea.	3/8-16x1 Button Head Bolt
4 ea.	3/8-16 Nyloc Nut

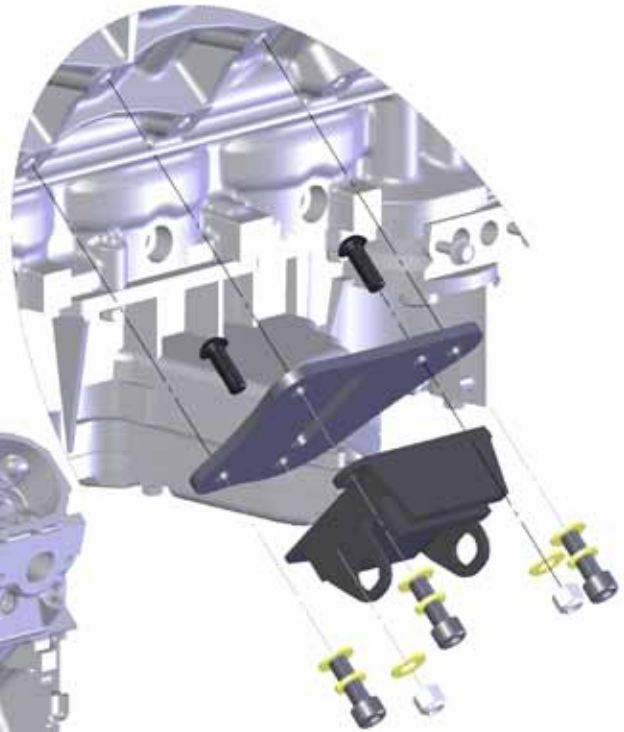
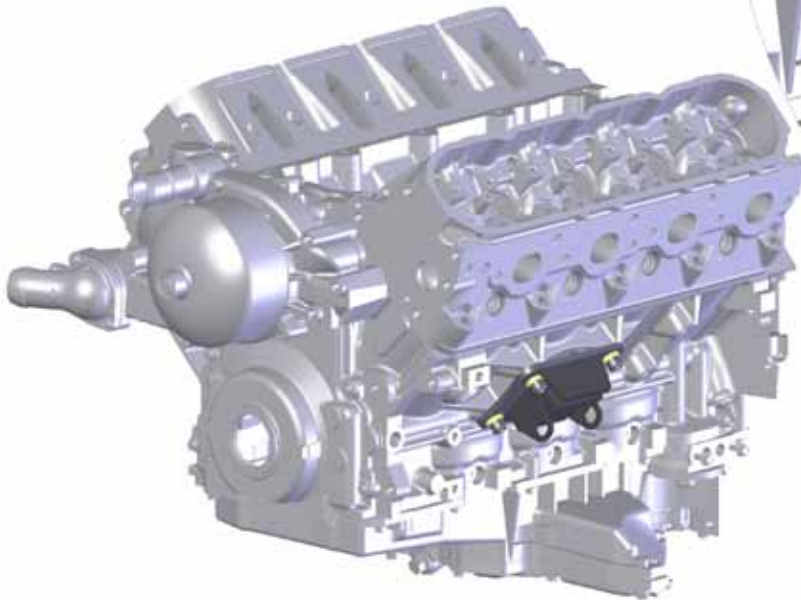

Note: This kit is intended to adapt the LS1 Engine to the standard Chevrolet V8 mount style.

Instructions:

1. Attach the engine mount adapters to the engine mounts with the button head screws. The forward upper hole will be bolted in later. The screw heads will be against the adapter and the flat washers will be between the rubber mount and the Nyloc nuts. ***Do not use a washer between the head of the bolt and the adapter or the bolt head might interfere with the engine block!***
2. Using the M10x1.5x30mm socket head cap screws, the lock washers and flat washers, bolt the mounts and adapters to the engine block. The upper forward bolt will go thru both the adapter and the mount.

For technical help call Classic Performance Products Monday thru Friday 8:30am to 5:00pm at (714) 522-2000.

Classic Performance Products, Inc. 714.522.2000 | fax 714.522.2500
378 E. Orangethorpe Ave. | Placentia, CA 92870 | www.classicperform.com

Rev. 2/10/2010