



Steering, Brake & Suspension Specialists

#CP50000 - Power Steering Box Installation Instructions for 1955-57 Fullsize GM Car

Parts List:

1 ea	CP50000 Steering Box
3 ea	3/8-16x 3-1/2" Bolt
3 ea	3/8 Lock Washer
3 ea	3/8 Flat Washer

Notes:

This kit is designed to work with manual steering center link.

Instructions:

1. Remove the pitman arm from the steering box.
2. Remove the pressure and return hoses from the steering box.
3. Remove the coupler (rag joint or U-joint) from the steering box.
4. Remove the steering box from the car.

5. Bolt the new steering box to the frame.
6. Check that the front of the steering box is not making contact with the edge of the frame. If the steering box is making contact with the frame, the edge of the frame may need to be altered slightly for clearance. The diagram illustrates where some frames will interfere with the steering box. **Warning: Do not attempt to grind or modify the steering box!**
7. Connect the coupler (rag joint or U-joint).
8. Connect the pressure and return fittings.
9. Install the pitman arm.
10. With the engine running, check for leaks at the hose fittings. To do this have someone in the car hold the steering wheel tight against the left and right steering stops. This will operate the box at full pressure.

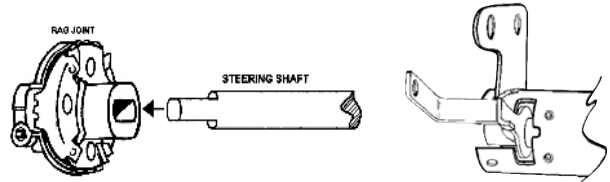

For Stock Column Installation:

Use CPP part #55570SCB-K when installing an original steering column with power steering conversion. *Note: Brackets will require welding.*

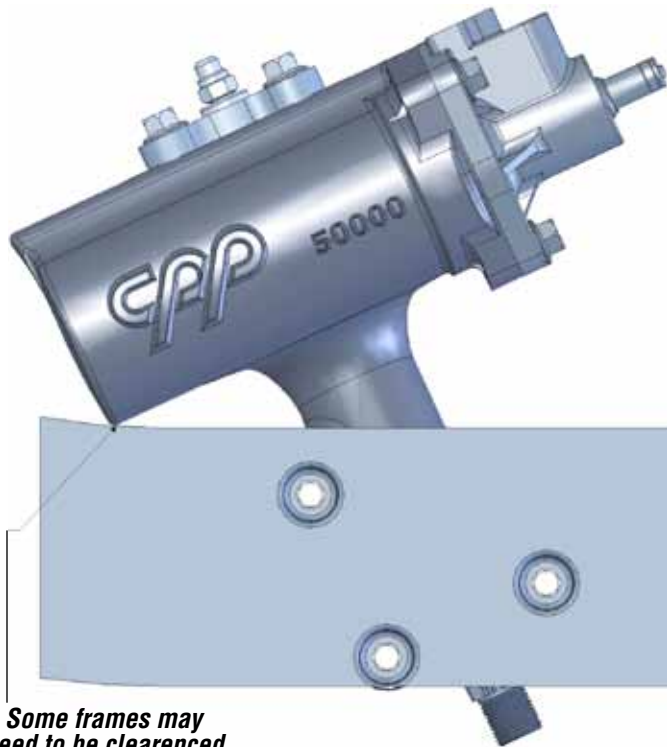

Some frames may need to be cleared here. Do not grind on the steering box!

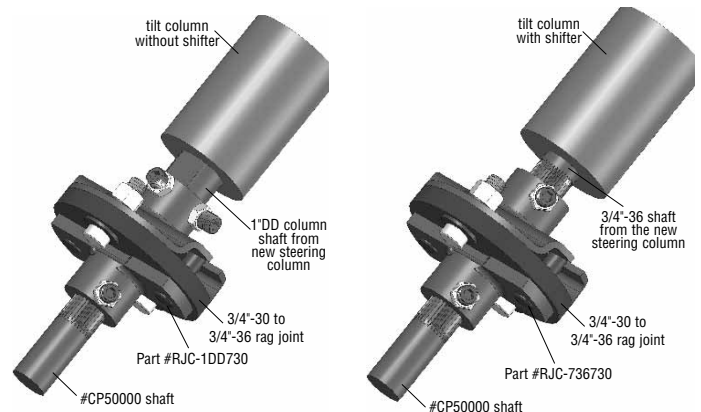

For Tilt Column Installation:

Tilt steering column installation kits are available. Use part #SCK-TP for tilt column without shift. Use part #SCK-SP for tilt column with shift.

For technical help call Classic Performance Products Monday thru Friday 8:30am to 5:00pm at (714) 522-2000.

Classic Performance Products, Inc. 714.522.2000 | fax 714.522.2500

378 E. Orangethorpe Ave. | Placentia, CA 92870 | www.classicperform.com