

*Steering, Brake & Suspension Specialists*

## #CP11200 - Installation Instructions for 1955-57 Steering Column Firewall Plate

### Parts:

1 ea	Firewall Plate
1 ea	2" Hose Clamp
1 ea	Foam Gasket
2 ea	5/16-18x3/4 Bolt
2 ea	5/16 Lock Washer
2 ea	5/16 Flat Washer

- Loosely attach the top of the steering column to the bottom of the dash.
- Connect the steering column to the steering box.
- Tighten the bolts securing the top of the steering column to the dash.
- Using the 5/16" hardware bolt the firewall plate to the firewall.
- Secure the bottom of the steering column to the firewall plate using the supplied clamp. Alternatively, the column can be secured with a sheet metal screw (not included) thru the hole in the tab on the firewall plate and into the steering column.

### Instructions:

- Manual transmission cars using the original clutch push rod will need to remove the knock out panel on the firewall plate.
- Apply the adhesive backed foam gasket to the fire wall side of the firewall plate. The gasket is perforated for the clutch rod knockout.
- Pass the steering column and clutch rod (if needed) thru the firewall plate.

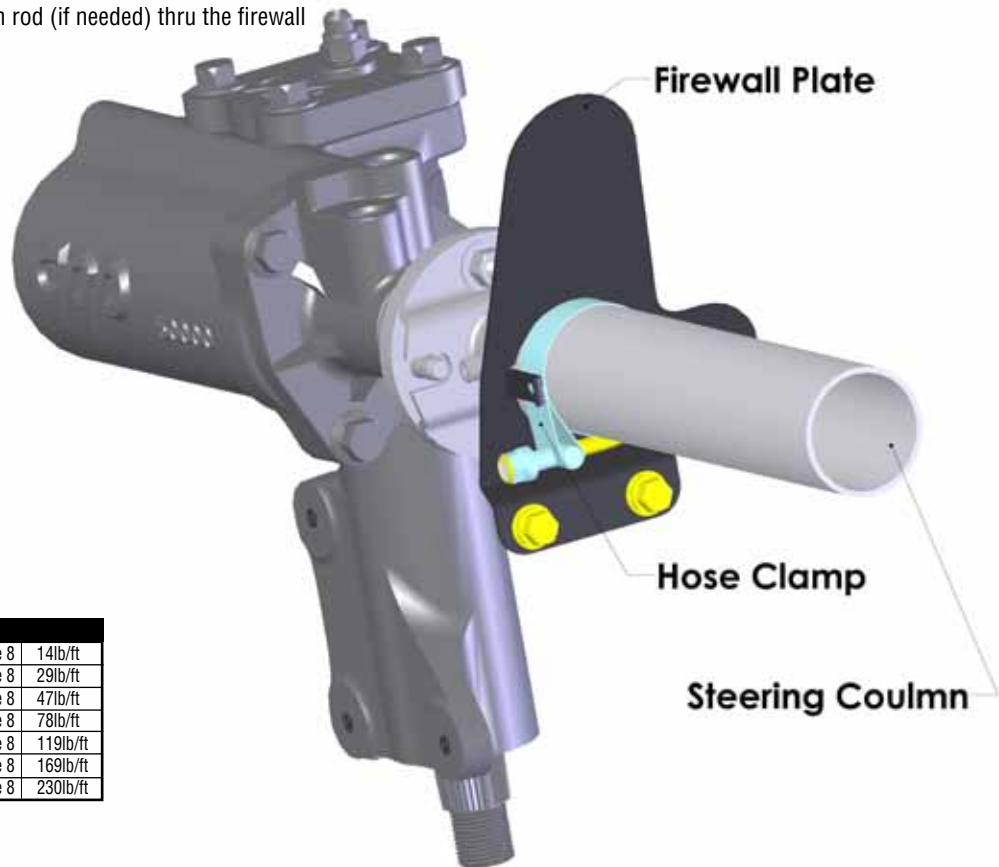

### GENERAL TORQUE SPECIFICATIONS:

1/4"	grade 5	10lb/ft	1/4"	grade 8	14lb/ft
5/16"	grade 5	19lb/ft	5/16"	grade 8	29lb/ft
3/8"	grade 5	33lb/ft	3/8"	grade 8	47lb/ft
7/16"	grade 5	54lb/ft	7/16"	grade 8	78lb/ft
1/2"	grade 5	78lb/ft	1/2"	grade 8	119lb/ft
9/16"	grade 5	114lb/ft	9/16"	grade 8	169lb/ft
5/8"	grade 5	154lb/ft	5/8"	grade 8	230lb/ft

**For technical help call Classic Performance Products Monday thru Friday 8:30am to 5:00pm at (714) 522-2000.**

**Classic Performance Products, Inc. 714.522.2000 | fax 714.522.2500**

378 E. Orangethorpe Ave. | Placentia, CA 92870 | [www.classicperform.com](http://www.classicperform.com)