



Steering, Brake & Suspension Specialists

#6472WBK-13 - Installation Instructions for 1962-1974 GM "A", "F", and "X" Body 13" Brake Kit

Parts List:

1 ea. 13" Left Rotor	2 ea. Spindle Dust Caps
1 ea. 13" Right Rotor	2 ea. 5/8-18 Anchor Bolts
1 ea. Left Brake Bracket	2 ea. 1/2-20x3" Steering Arm Bolts
1 ea. Right Brake Bracket	2 ea. 1/2-20 Self Locking Nuts
1 ea. Left Caliper Assy.	2 ea. Cotter Pins
1 ea. Right Caliper Assy.	2 ea. 10mm Banjo Bolts
2 ea. Hub Assemblies	4 ea. 10mm Banjo Bolt Washers
2 ea. Outer Wheel Bearings	4 ea. M14x2.0x40mm Gr. 8.8
2 ea. Spindle Washers	4 ea. 9/16" Lock Washers
2 ea. Spindle Nuts	4 ea. 1/2" Flat Washers
2 ea. Brake Hoses	
2 ea. Brake Hose Clips	

Notes:

This kit is designed to work with 17" or larger wheels.

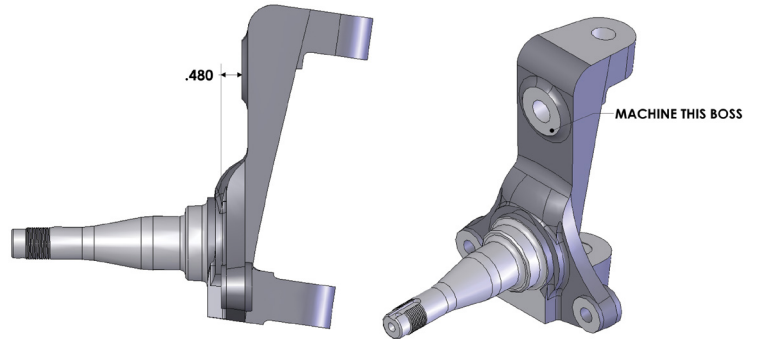

O.E. drum brake spindles will need to be modified into a disc type spindle. This is done by cutting the boss for the upper anchor bolt .60 inches shorter. The anchor bolt threads may need to be changed to 5/8-18 if they are not already.

Replacement Parts:

- Brake Calipers: 1999-2004 GM 1/2 ton pickup & SUV w/ 6 lug wheels
- Brake Pads: 1999-2004 GM 1/2 ton pickup & SUV w/ 6 lug wheels
- Left Rotor: CPP 13" 31815 Left Rotor
- Right Rotor: CPP 13" 31815 Right Rotor

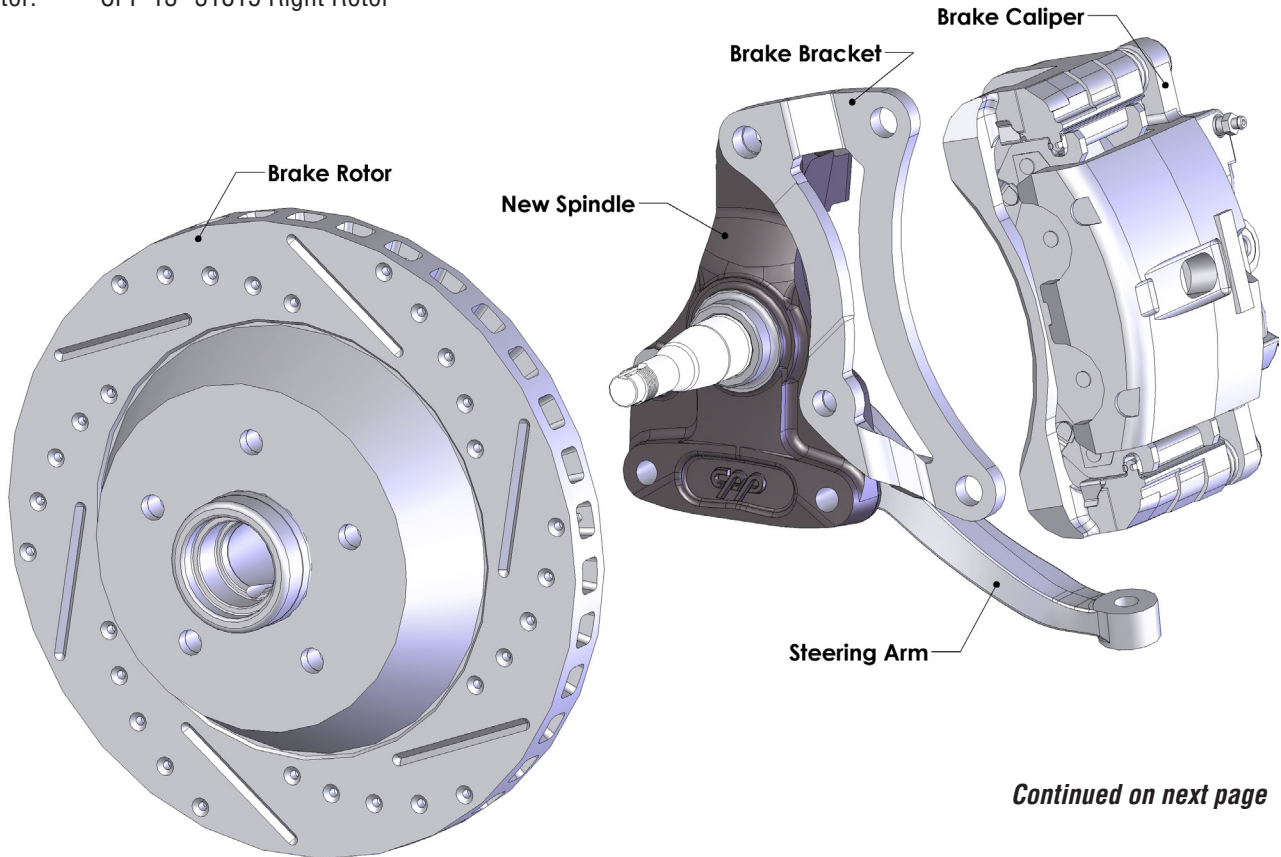

Continued on next page



Steering, Brake & Suspension Specialists

#6472WBK-13 - Installation Instructions (Continued)

Instructions:

1. Disconnect the brake hoses from the hard line. (New brake hoses are included with the disk brake kit.)
2. Remove the rotors, O.E. brake brackets, and the backing plates.
3. Install the new brake brackets using the new 5/8-18 anchor bolts and the new 1/2-20x3" bolts.
4. Install the new hub assemblies.
5. Install the rotors onto the hubs.
6. Install the caliper assemblies. The bleed screws will be towards the top. Torque the caliper mounting bolts to 100 lbs/ft.
7. Check that the hub can turn freely and that the brakes do not drag.
8. Connect the new brake hoses to the calipers, and the hard lines. Secure the brake hoses to the frame with the brake hose clips.
9. Bleed the brakes.

PLEASE NOTE: The installer needs to make sure that nothing can make contact with a brake hose, caliper, or other brake component at any point through the entire range of steering and suspension movement. The installer also needs to make sure none of the steering or braking components can become bound or jammed at any time through the range of suspension or steering movement.

© Classic Performance Products, Inc. 2015
All rights reserved. This document may not be reproduced without prior written permission of CPP.

GENERAL TORQUE SPECIFICATIONS:					
1/4"	grade 5	10lb/ft	1/4"	grade 8	14lb/ft
5/16"	grade 5	19lb/ft	5/16"	grade 8	29lb/ft
3/8"	grade 5	33lb/ft	3/8"	grade 8	47lb/ft
7/16"	grade 5	54lb/ft	7/16"	grade 8	78lb/ft
1/2"	grade 5	78lb/ft	1/2"	grade 8	119lb/ft
9/16"	grade 5	114lb/ft	9/16"	grade 8	169lb/ft
5/8"	grade 5	154lb/ft	5/8"	grade 8	230lb/ft

NOTE: With 18" and larger wheels we recommend 1/2" wheel studs. The larger the wheel diameter, the greater the force is on the wheel studs. Please inquire about replacement wheel stud kits available from CPP.