



Steering, Brake & Suspension Specialists

#6372TCA-UK - Installation Instructions

1963-1987 Tubular Upper Control Arms

Parts List:

- 1 ea Left Upper Control Arm Assembly
- 1 ea Right Upper Control Arm Assembly
- 2 ea Bump Stops
- 2 ea 3/8-16 Nyloc Nuts
- 2 ea 3/8 flat washers

Note:

The control arms are built to provide 5° of caster. CPP recommends new ball joints, available from CPP.

Warning:

Do not remove the cross shaft bolts. They are installed with Loctite. Removing the cross shaft bolts will void the warranty.

Instructions:

1. Remove the original upper control arms.
2. Install the new upper control arm assemblies. The straight tube will be towards the front of the car. CPP recommends using new ball joints.
3. Install the bump stops in the control arms.
4. Have the truck professionally aligned.

PLEASE NOTE: The installer needs to make sure that nothing can make contact with a brake hose, caliper, or other brake component at any point through the entire range of steering and suspension movement. The installer also needs to make sure none of the steering or braking components can become bound or jammed at any time through the range of suspension or steering movement.

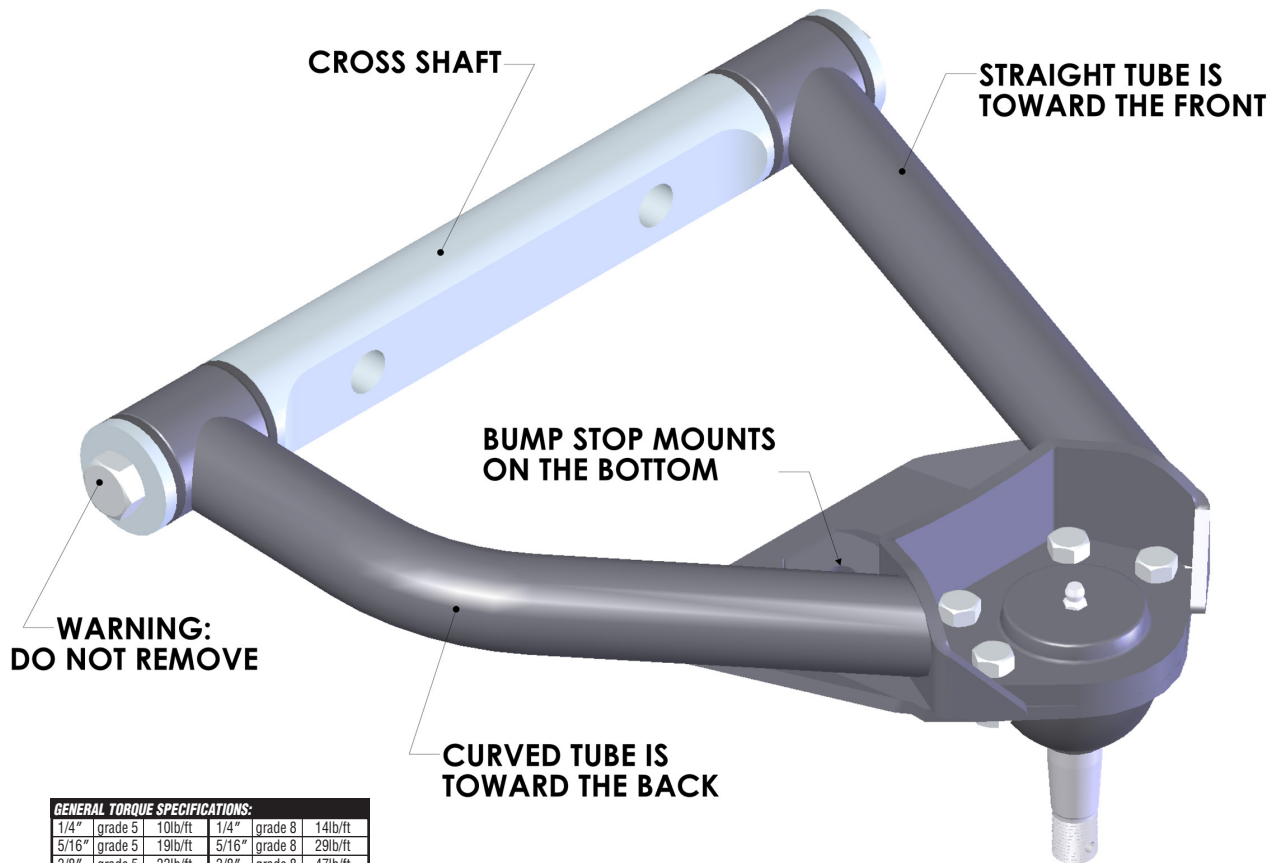

GENERAL TORQUE SPECIFICATIONS:

1/4"	grade 5	10lb/ft	1/4"	grade 8	14lb/ft
5/16"	grade 5	19lb/ft	5/16"	grade 8	29lb/ft
3/8"	grade 5	33lb/ft	3/8"	grade 8	47lb/ft
7/16"	grade 5	54lb/ft	7/16"	grade 8	78lb/ft
1/2"	grade 5	78lb/ft	1/2"	grade 8	119lb/ft
9/16"	grade 5	114lb/ft	9/16"	grade 8	169lb/ft
5/8"	grade 5	154lb/ft	5/8"	grade 8	230lb/ft

NOTE: With 18" and larger wheels we recommend 1/2" wheel studs. The larger the wheel diameter, the greater the force is on the wheel studs. Please inquire about replacement wheel stud kits available from CPP.

© Classic Performance Products, Inc. 2015
All rights reserved. This document may not be reproduced without prior written permission of CPP.