



Steering, Brake & Suspension Specialists

#6062DBK & #6370DBK Installation Instructions

1960-62 & 1963-70 Chevy Truck Disc Brake Conversion

Parts List:

- ROTORS: 69-72 Chevelle or GM Equivalent
 CALIPERS: 70-81 Camaro or GM Equivalent (when supplied, uses 79-81 Camaro with 10mm Banjo Bolts)
 BEARINGS & SEALS: A2 Outer Bearings
 A13 Inner Bearings
 8705S Bearing Seals
 MOUNTING HARDWARE

Note:

Read these instructions completely before attempting this conversion!!!

BEFORE BEGINNING INSTALLATION, MAKE SURE YOUR WHEELS FIT ON THE DISC ROTOR.

Make sure this kit fits your application before painting or plating. Parts that have been painted, plated or modified may not be returned.

Instructions:

1. Remove the old drum brake assemblies so all that remains are the stock spindles. Inspect the bearing surfaces on the spindle. If the spindle is grooved, a piece of 180-grit emery cloth can be used to clean it up.
2. Install the bearing adapter onto the spindle. The adapter may need to be heated so it can expand for easier installation. This can be achieved placing it in boiling water or setting it on a light bulb for about 5 minutes.
3. Install the caliper mounting bracket on the spindle with the caliper opening toward the rear of the truck.
4. Take the inner bearing and slide it onto the spindle. If the bearing will not go on, use a piece of 180-grit emery cloth take down the spindle.
Note: If the bearing adapter can spin on the axle shaft, you can install the adapter with a small amount of red Loctite.

5. Remove stock inner race from rotor and replace it with the race supplied in the A13 bearing set. Grease all bearings and install them with the grease seal.
6. Install the rotor onto the spindle and tighten the spindle nut. Install the cotter pin and dust cap.
7. Install caliper with the bleeder pointing up. Make sure everything is good and tight and proceed to bleed the system.

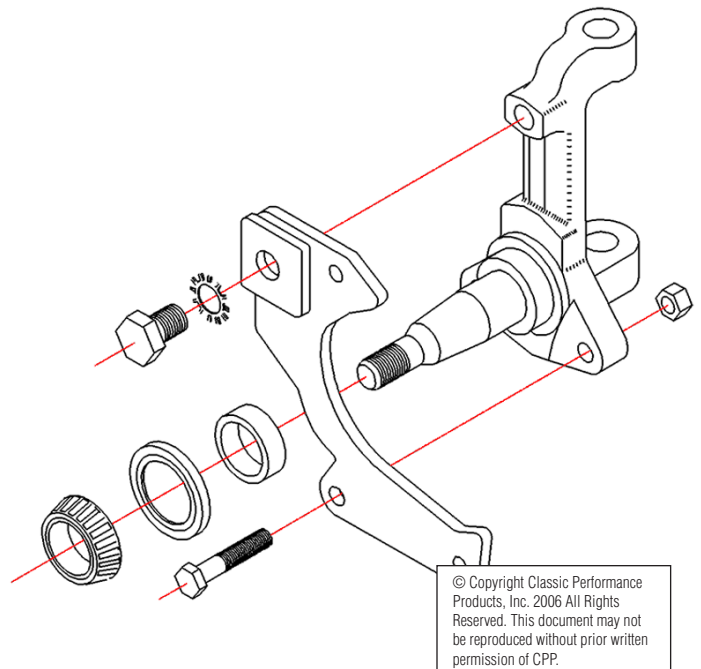

For technical help call Classic Performance Products Monday thru Friday 8:30am to 5:00pm at (714) 522-2000.

Classic Performance Products, Inc. 714.522.2000 | fax 714.522.2500
 175 E. Freedom Avenue | Anaheim, CA 92801 | www.classicperform.com