

*Steering, Brake & Suspension Specialists*

## #5559FBB - Firewall Mount Brake Kit Instructions for 1955-59 Chevy Truck

### Parts:

1 - Power Brake Booster	1 - Strut Rod Stabilizer
1 - Master Cylinder	1 - Pedal Push Rod Assembly
1 - Booster Mounting Bracket	1 - Hardware Kit

### Notes:

Read these instructions completely before attempting this conversion.

Make sure this kit fits your application before painting or plating. Beware that chroming or painting the booster can cause it to malfunction if not performed properly. Parts that have been painted, plated or modified may not be returned.

### Instructions:

Installation of this kit requires the removal of the stock steering column brace. The stock steering column brace is the shaded area in FIG 1. The spot welds need to be broken or drilled out to remove this brace.

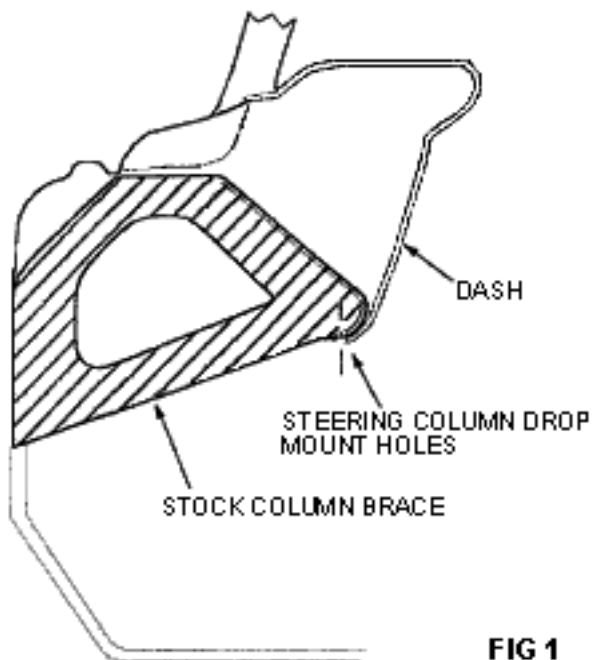

FIG 1

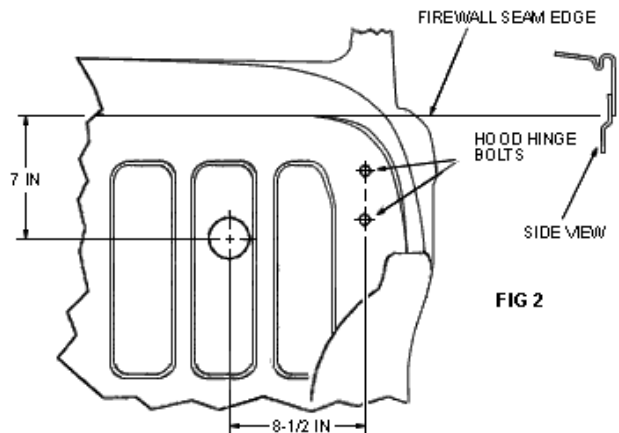

FIG 2

When the brace is removed, a 2-1/2" hole must be drilled with a hole saw 7" from the firewall seam edge and 8-1/2" in from the hood hinge bolts. Mount the brackets to the steering column drop mount holes. Line up the 2-1/2" holes in the bracket and the firewall and clamp in place. Use the bracket as a guide to drill the 1/2" mounting holes.

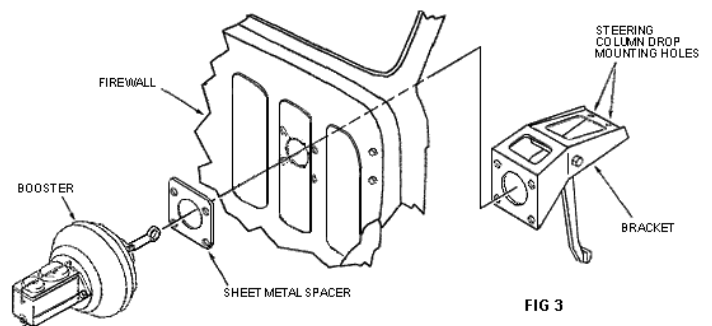

FIG 3

**For technical help call Classic Performance Products Monday thru Friday 8:30am to 5:00pm at (714) 522-2000.**

**Classic Performance Products, Inc. 714.522.2000 | fax 714.522.2500**

378 E. Orangethorpe Ave. | Placentia, CA 92870 | [www.classicperform.com](http://www.classicperform.com)