

*Steering, Brake & Suspension Specialists*

## #5557USC - Universal Shock Crossmember Instructions for 1955-57 Fullsize Car

### Notes:

Read these installation instructions completely before attempting this installation.

Make sure this kit fits your application before painting or plating. Parts that have been painted, plated or modified may not be returned.

### Instructions:

1. Jack up the rear of the car and support it with jackstands. Proceed to remove the shocks.
2. Assemble the Universal Shock Crossmember with the supplied hardware and "L" brackets. With it assembled, put it in the location that

you want it and mark where the holes are to be drilled. Make sure that the placement of the shock crossmember will not cause the shocks to bind in any part of the stroke.

3. With the frame marked drill your holes. Be sure to drill a pilot hole so the drill bit will not walk.
4. Install the crossmember on the car.
5. Install the shocks. Make sure that the shocks are not binding. If all is good, lower the from the jackstands and enjoy.

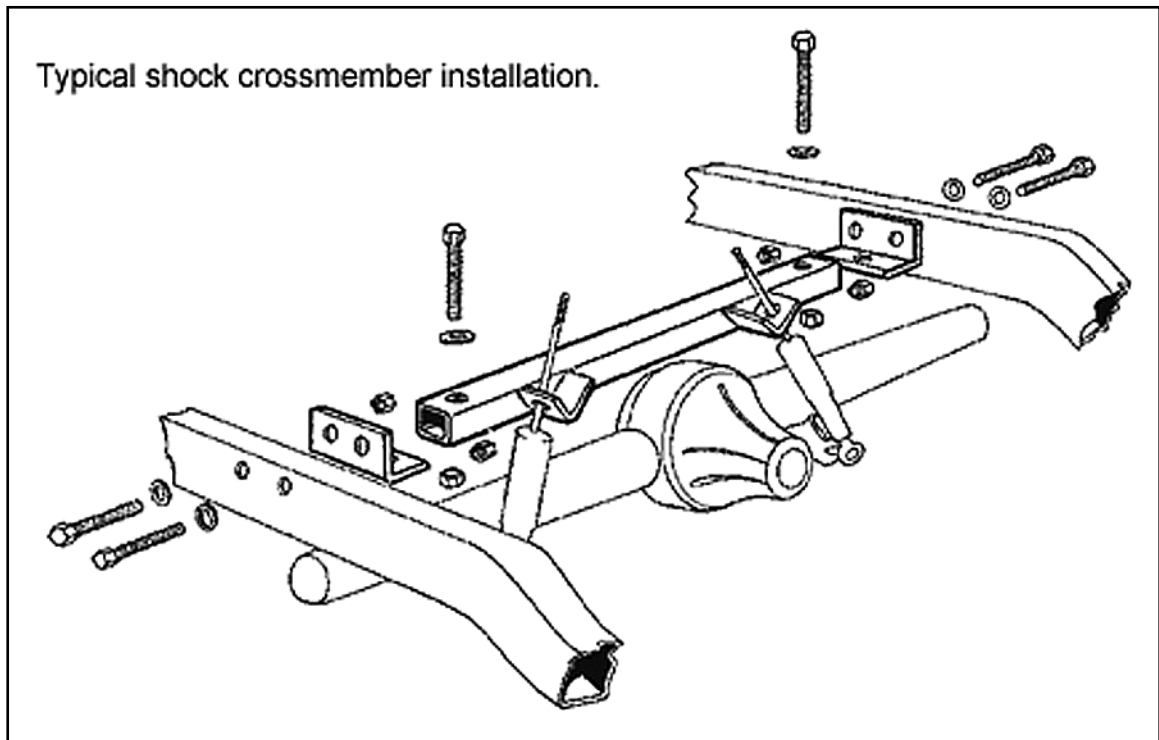

*For technical help call Classic Performance Products Monday thru Friday 8:30am to 5:00pm at (714) 522-2000.*

**Classic Performance Products, Inc. 714.522.2000** | fax 714.522.2500

378 E. Orangethorpe Ave. | Placentia, CA 92870 | [www.classicperform.com](http://www.classicperform.com)