

Steering, Brake & Suspension Specialists

#5356HST - Hood Hinge Spring Tool Instructions

Note:

Read these instructions completely before attempting this conversion.

Instructions:

1. Remove and inspect your old hood hinges.
2. Install the nuts on the hood hinge mounting studs to protect the threads on the studs, then place the hood hinge in a strong vice.
3. Place the tool over the old spring with spring hooked in the tool notch (A). Holding the tool down, slowly turn the tool until the spring comes away from stop (A). Tilt the tool and the spring slightly and let the spring release into the tool. Remove the old spring from the tool by tapping it out. This should be done down in a trash can to contain the spring in case it jumps.
4. Place the new spring on the hinge in the same direction the old one came off, place the hinge tool over the new spring and wind it back over the spring stop. (A)

Note: You should look your hood hinges over carefully for bad rivets, cracks and bent areas. Pay close attention to area (B). If this area is not properly hooked it could cause the spring to unwind. (Watch out!)

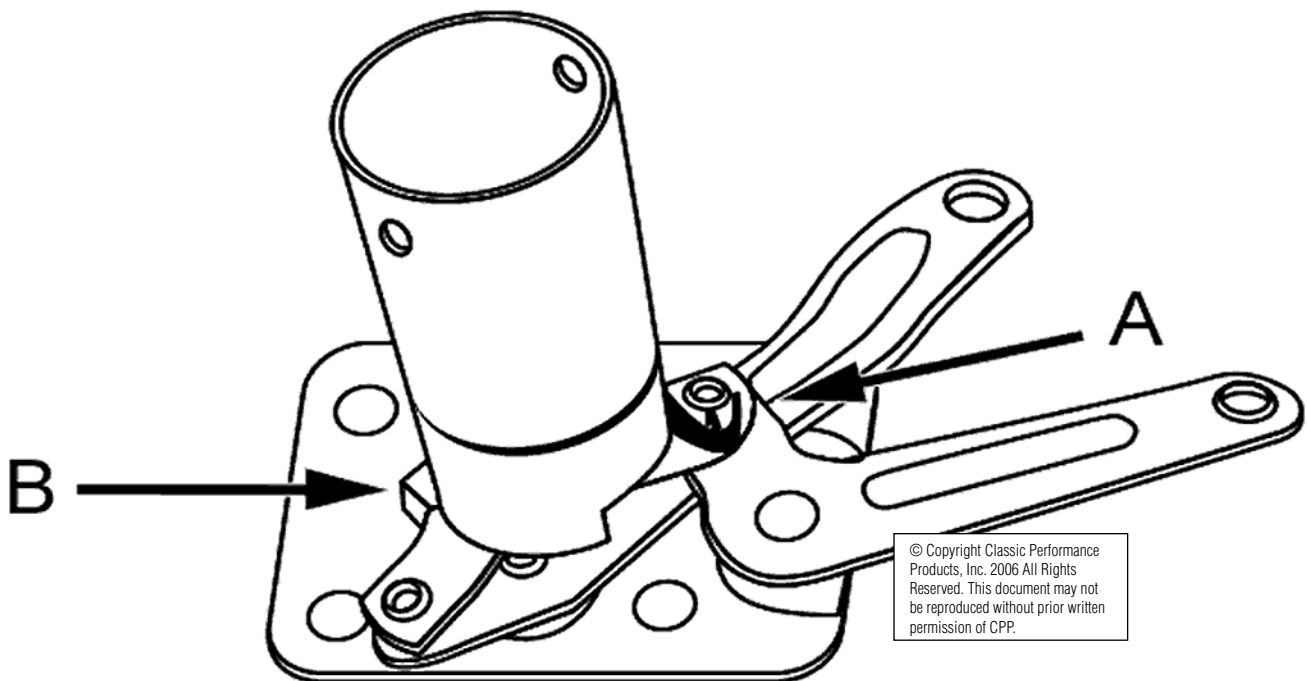

For technical help call Classic Performance Products Monday thru Friday 8:30am to 5:00pm at (714) 522-2000.

Classic Performance Products, Inc. 714.522.2000 | fax 714.522.2500

378 E. Orangethorpe Ave. | Placentia, CA 92870 | www.classicperform.com