

#5356BB - Installation Instructions

for 1953-56 Ford Truck Brake Booster Adapter

Notes:

This kit is designed to work with the original floor brake pedal. This factory clutch linkage will not work with this booster kit. Make sure this kit fits your application before painting or plating. Parts that have been painted, plated, or modified may not be returned.

Instructions:

1. Disconnect the brake lines from the master cylinder and disconnect the pedal rod from the pedal assembly. Remove the original master cylinder and pedal rod.
2. Bolt the brake booster adapter bracket to the frame where the stock master cylinder used to mount. The Ford application will use the outer mounting hole. The flange that the new brake booster will mount to should be towards the rear of the truck. One bolt will be a fine thread 1 1/4" long 3/8" bolt that goes into a nut attached to the frame. The other bolt will be a coarse thread 1 1/4" long 3/8" bolt with a nut. One flat washer goes beneath each bolt head. One lock washer and one lock washer go beneath the nut.

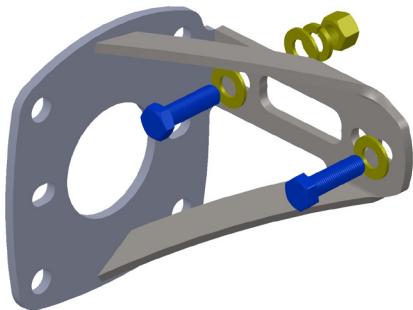

3. Make sure the booster is configured correctly to work with the master cylinder. A master cylinder bore adapter may be needed in the case of a deep bore master cylinder. Most boosters require a shallow bore master cylinder. All manual master cylinders have a deep bore.
4. Attach the booster to the bracket.

5. Bench bleed the master cylinder. Follow the brake bleeder kit instructions. Plug the line holes to prevent air from getting in and fluid from dripping. Put the lid on the master cylinder to avoid spilling and fluid contamination.

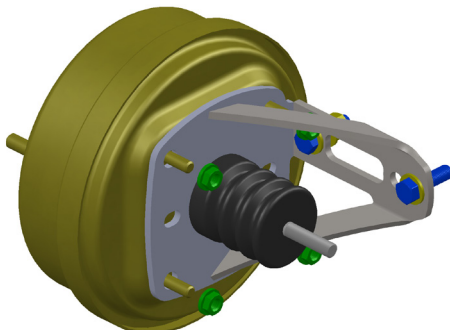

6. Bolt the master cylinder and proportioning valve bracket (when used) to the brake booster using the hardware supplied with the booster. (CPP recommends #MCPVU-2 disc drum m/c or #MCPVU-4 disc disc m/c units.) Make sure that the brake booster is not preloading the master cylinder. The booster push rod should be as close as possible without preload.

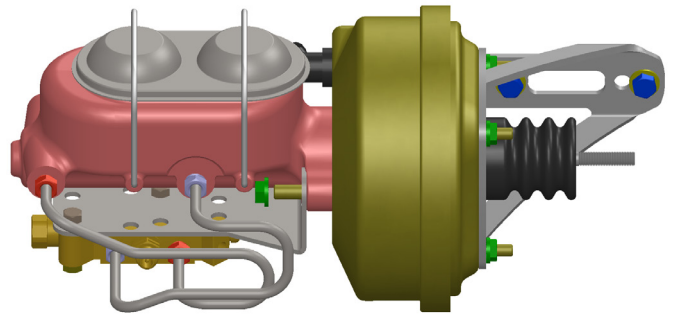

7. The factory clutch linkage will not work with this kit. Remove the factory clutch pedal and replace the pedal bolt assembly with the provided pedal bolt kit so that the brake pedal will still line up properly with the master cylinder and pedal rod.
8. Assemble the pedal rod. Thread a 3/8" nut and then the cut end of the female push rod onto the booster push rod. Then thread a 7/16" nut onto the rod end. Thread the rod end into the other end of the female push rod.

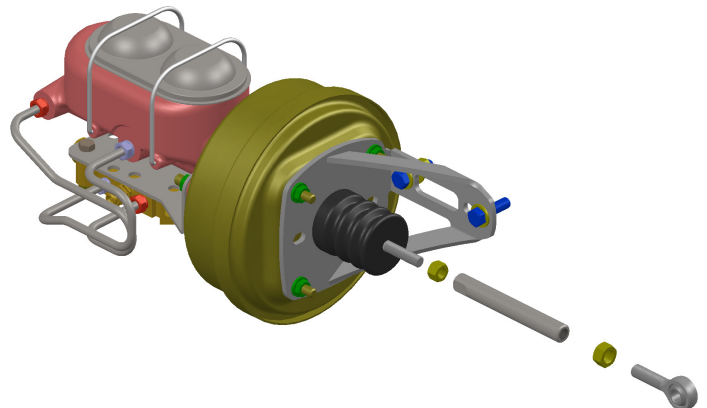

#5356BB - Installation Instructions (Continued)

9. Adjust the overall length of the pedal rod assembly. With the pedal in its full up position, the rod end should line up with the pedal hole. The length is changed by screwing the rod end further in or out of the female push rod or by threading the female push rod further on or off of the rod coming out of the booster. The booster and master cylinder should never be preloaded. When the pedal is in the full up position, the rod should be applying no pressure on the booster or master cylinder. There should be almost no play before the rod begins to apply pressure on the booster and master cylinder. When there is no preload, tighten the jam nuts.

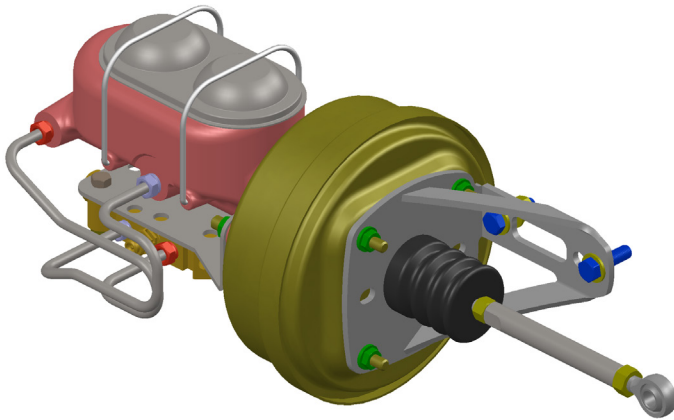
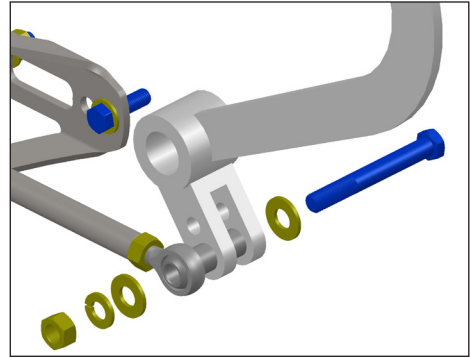

10. Attach the pedal rod to the pedal assembly. The bolt passes through a washer, the (larger) pedal hole, a 1/2" spacer, the second pedal hole, the second 1/2" spacer, the rod end, a second washer, a lock washer, and finally a nut in this order as shown in the illustration. Double check that the brake booster has no preload. Readjust the pedal rod length if necessary.

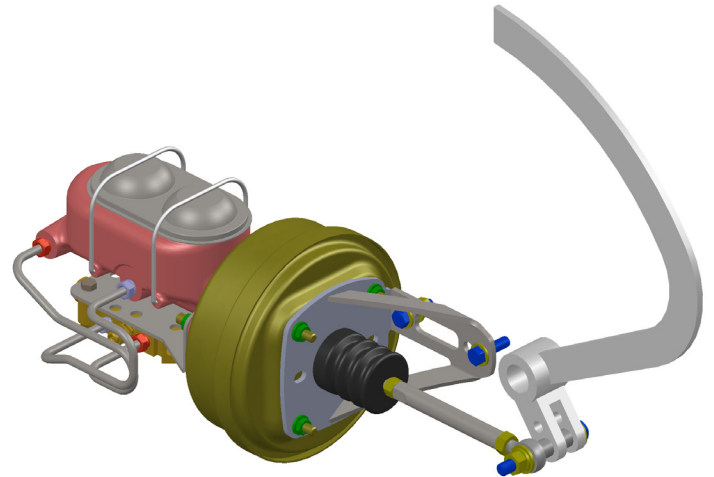

11. Plumb the brake lines.

12. Bleed the brakes.

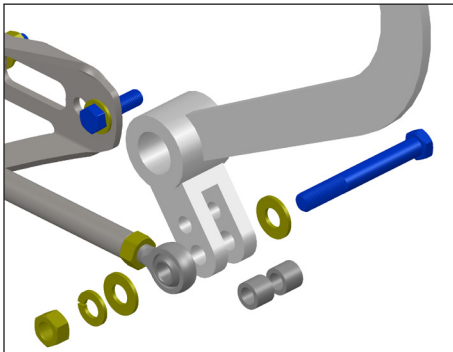

GENERAL TORQUE SPECIFICATIONS:					
1/4"	grade 5	10lb/ft	1/4"	grade 8	14lb/ft
5/16"	grade 5	19lb/ft	5/16"	grade 8	29lb/ft
3/8"	grade 5	33lb/ft	3/8"	grade 8	47lb/ft
7/16"	grade 5	54lb/ft	7/16"	grade 8	78lb/ft
1/2"	grade 5	78lb/ft	1/2"	grade 8	119lb/ft
9/16"	grade 5	114lb/ft	9/16"	grade 8	169lb/ft
5/8"	grade 5	154lb/ft	5/8"	grade 8	230lb/ft

NOTE: With 18" and larger wheels we recommend 1/2" wheel studs. The larger the wheel diameter, the greater the force is on the wheel studs. Please inquire about replacement wheel stud kits available from CPP.

© Classic Performance Products, Inc. 2013
All rights reserved. This document may not be reproduced without prior written permission of CPP.