

Steering, Brake & Suspension Specialists

#5355FBB - Firewall Mount Brake Kit Instructions for 1953-55 Ford Trucks

Notes:

Make sure this kit fits your application before painting or plating. Beware that chroming or painting the booster can cause it to malfunction if not performed properly. Parts that have been painted, plated or modified may not be returned.

Instructions:

1. Use a 2-1/2" hole saw to cut the center hole for the booster 7" down from the firewall seam centered on the first rib. Use the sheet metal spacer as a guide to drill the remaining 1/2" mounting holes.

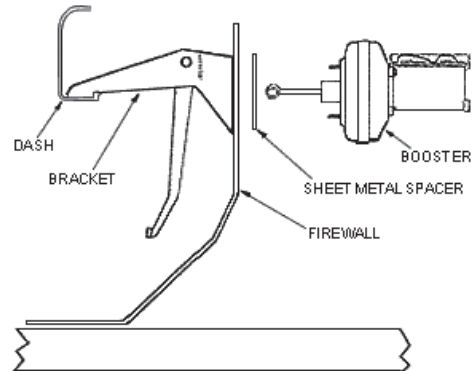
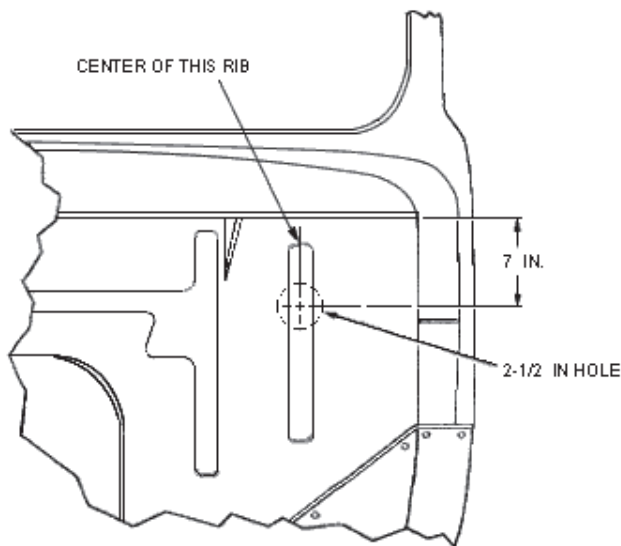

2. When all the holes are drilled, mount the booster and pedal assembly as shown to the firewall and dash. (Steering column drop mount holes)

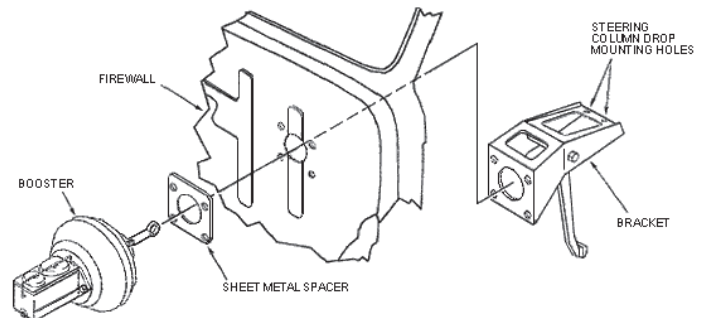

For technical help call Classic Performance Products Monday thru Friday 8:30am to 5:00pm at (714) 522-2000.

Classic Performance Products, Inc. 714.522.2000 | fax 714.522.2500

175 E. Freedom Avenue | Anaheim, CA 92801 | www.classicperform.com