



Steering, Brake & Suspension Specialists

# #4856DBK-4.75 - Disc Brake Conversion Instructions for 1948-56 Ford F-100 (5 on 4-3/4" Bolt Circle)

### Parts List:

ROTORS:  
70-77 Camaro  
CALIPERS:  
70-77 Camaro

BEARINGS & SEALS:  
A2 Outer Bearings  
A13 Inner Bearings  
8871 Bearing Seals  
MOUNTING HARDWARE

### Notes:

On some applications it may be necessary to drill the lower spindle holes from 7/16" to 1/2".

Read these instructions completely before attempting this conversion.

BEFORE BEGINNING INSTALLATION, MAKE SURE YOUR WHEELS FIT ON THE DISC ROTOR.

Make sure this kit fits your application before painting or plating. Parts that have been painted, plated or modified may not be returned.

### Instructions:

1. Remove the drum and backing plate assemblies from the stock spindles. Inspect the bearing surfaces on the spindle. If the spindle is grooved, a piece of 180-grit emery cloth can be used to clean it up.
2. Install the bearing adapters onto the spindles. *Note: If the bearing adapter can spin on the axle shaft, you can install the adapter with a small amount of red Loctite.*
3. Install the caliper mounting bracket on the back side of the spindle with the caliper opening pointing towards the rear of the truck, using the bolts, lock washers (spacers) and nuts supplied. The lock washers act as a spacer and are installed between the bracket and spindle.

4. Slide the caliper onto the bracket with the bleeder up. The caliper may not slide into place due to a bump in the casting next to the piston bore. In some cases, it will be necessary to grind this bump flush using a bench grinder. Reinstall the caliper and turn the spindle full lock left and right to check for any interference. The caliper bracket should clear the king pin locknut. If not, reverse the king pin nut so that it is on the front side of the axle.
5. Remove caliper from bracket.
6. If you purchased your rotors from someone other than CPP, remove stock inner race from the rotors and replace them with the races supplied in the A-13 bearing set. Pack all of the bearings with grease, and install the inner bearings and seals into the rotors.
7. Install the rotors onto the spindle first then install the outer bearings, spindle washer, spindle nut spacer, and the spindle nut. Adjust the wheel bearing clearance, install the cotter pin and dust cap.
8. Install the calipers with the bleed screws up.
9. Double check that all of the bolts are tight and proceed to bleed the brake system.

**WARNING!!** Stock drum brake wheels may not work with disc brake conversions. Drum brake wheels were not made with disc brakes in mind so there may be wheel to caliper clearance problems. Before installing this kit, make sure your wheels fit the brake assembly.

For those wanting to keep stock wheels that interfere with the installation, there are companies such as Wheelsmith, Stockton Wheel Co. and Wheel Vintiques that can remove the original wheel centers and re-install them into a new disc brake rim. Please call for more information.

Wheelsmith (951) 898-4563 | Wheel Vintiques (800) 2959-2100 | Stockton Wheel Service (209) 464-7771

**PLEASE NOTE:** The installer needs to make sure that nothing can make contact with a brake hose, caliper, or other brake component at any point through the entire range of steering and suspension movement. The installer also needs to make sure none of the steering or braking components can become bound or jammed at any time through the range of suspension or steering movement.

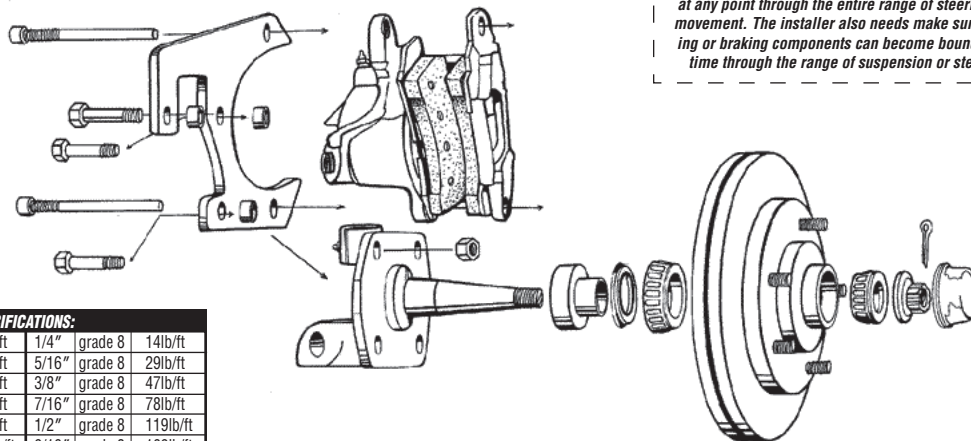

### GENERAL TORQUE SPECIFICATIONS:

1/4"	grade 5	10lb/ft	1/4"	grade 8	14lb/ft
5/16"	grade 5	19lb/ft	5/16"	grade 8	29lb/ft
3/8"	grade 5	33lb/ft	3/8"	grade 8	47lb/ft
7/16"	grade 5	54lb/ft	7/16"	grade 8	78lb/ft
1/2"	grade 5	78lb/ft	1/2"	grade 8	119lb/ft
9/16"	grade 5	114lb/ft	9/16"	grade 8	169lb/ft
5/8"	grade 5	154lb/ft	5/8"	grade 8	230lb/ft

NOTE: With 18" and larger wheels we recommend 1/2" wheel studs. The larger the wheel diameter, the greater the force is on the wheel studs. Please inquire about replacement wheel stud kits available from CPP.

© Classic Performance Products, Inc. 2015  
All rights reserved. This document may not be reproduced without prior written permission of CPP.