



Steering, Brake & Suspension Specialists

#4759DBK-5 - 5-Lug (5 on 4.75 car) Disc Brake Kit for 1947-59 Chevy Trucks

Parts List:

2 ea 1/2-20x3"	4 ea 1/2 flat washers
2 ea 1/2-20x2-1/2"	1 ea CP-36A set
4 ea 1/2-20 lock nuts	1 ea CP-36B set
4 ea 7/16-20x2"	1 ea 4759DB-5 (pair) bracket
4 ea 7/16-20 lock nuts	2 ea 1/4"-28x1/4 set screws
4 ea 7/16 flat washers	

Notes:

BEFORE BEGINNING INSTALLATION, MAKE SURE YOUR WHEELS FIT ON THE DISC ROTOR. ALSO, THIS KIT WORKS ONLY WITH 15" AND UP WHEELS DUE TO THE 11" ROTORS.

Instructions:

1. Remove the drum and backing plate assemblies so all that remains are the stock spindles. Inspect the bearing surfaces on the spindle. If the spindle is grooved, a piece of 180-grit emery cloth can be used to clean it up.
2. Install the bearing adapter onto the spindle.
3. The zerk grease fitting may need to be moved to clear the bracket as shown in the diagram to the right. Remove the zerk fitting and bolt on the caliper bracket. Mark a location on the spindle where the zerk fitting will clear the caliper bracket, typically, it is about 45 degrees further back than the original location. Remove the caliper brackets and re-insert the zerk fitting in the original location. Drill a hole in the marked location with a no. 3 drill (.2130) Don't worry! The king pin is case hardened, you won't damage it. Once the hole is drilled, tap the hole with a 1/4-28 NF tap. To clear the debris from the new location, pump grease through the zerk fitting at the stock location until you are confident it is clean. Move the zerk fitting to the new location and plug the old with the supplied 1/4-28 set screw.
4. Install the caliper mounting bracket on the front side of the spindle. Make sure the caliper opening is pointing towards the rear of the truck. The spacers provided in the kit go between the bracket and spindle. Be sure when attaching the caliper bracket to the spindle that the nuts are on the inside of the rotor. Also, the flat of the nut must be up against the shoulder of the spindle in order for the nut to seat correctly. This is very important.
5. Slide the caliper onto the bracket with the bleeder up. The caliper may not slide into place due to a bump in the casting next to the piston bore. In some cases, it will be necessary to grind this bump flush using a bench grinder. Reinstall the caliper and turn the spindle full lock left and right to check for any interference. The caliper bracket should clear the king pin locknut. If not, reverse it so the nut is on the front of the axle. Remove caliper from bracket.
6. Take the inner bearing and slide it onto the bearing adapter. If the bearing will not go on, use a piece of 180-grit emery cloth take down the adapter. *Note: If the bearing adapter can spin on the axle shaft, you can install the adapter with a small amount of red Loctite.*
7. Remove stock outer race from the rotor and replace it with the race supplied in the A2 bearing set. Grease all bearings and install them as well as the seals.

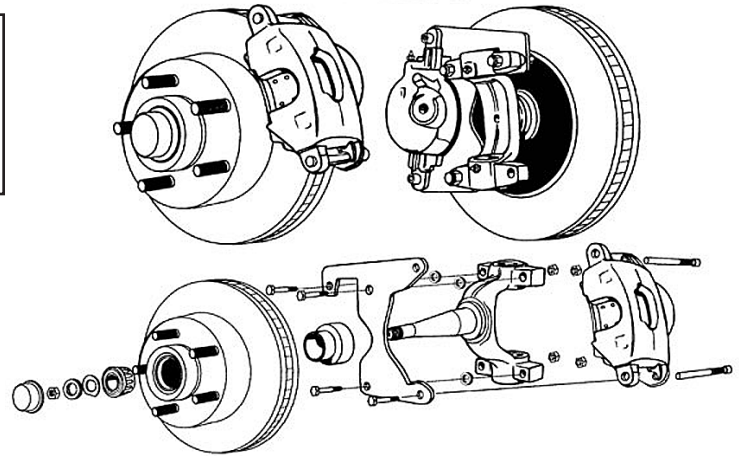

Note: If rotor was purchased from CPP, this has already been done.

8. Install the rotor onto the spindle and tighten the spindle nut. Install the cotter pin and dust cap.
9. Install caliper with the bleeder pointing up. Make sure everything is tight and proceed to bleed the system.
10. *NOTE: On some applications it may be necessary to drill the lower spindle holes from 7/16" to 1/2".

Warning!!

Stock drum brake wheels may not work with disc brake conversions. Drum brake wheels were not made with disc brakes in mind so there may be wheel to caliper clearance problems. Before installing this kit, make sure your wheels fit the brake assembly.

For those wanting to keep stock wheels that interfere with the installation, there are companies such as Wheelsmith, Stockton Wheel Co. and Wheel Vintiques that can remove the original wheel centers and re-install them into a new disc brake rim. Please call for more information.

Wheelsmith (714) 556-3861
Wheel Vintiques (209) 251-6957
Stockton Wheel Service (209) 464-7771

GENERAL TORQUE SPECIFICATIONS:

1/4"	grade 5	10lb/ft	1/4"	grade 8	14lb/ft
5/16"	grade 5	19lb/ft	5/16"	grade 8	29lb/ft
3/8"	grade 5	33lb/ft	3/8"	grade 8	47lb/ft
7/16"	grade 5	54lb/ft	7/16"	grade 8	78lb/ft
1/2"	grade 5	78lb/ft	1/2"	grade 8	119lb/ft
9/16"	grade 5	114lb/ft	9/16"	grade 8	169lb/ft
5/8"	grade 5	154lb/ft	5/8"	grade 8	230lb/ft

For technical help call Classic Performance Products Monday thru Friday 8:30am to 5:00pm at (714) 522-2000

Classic Performance Products, Inc. 714.522.2000 | fax 714.522.2500
175 E. Freedom Avenue | Anaheim, CA 92801 | www.classicperform.com