



Steering, Brake & Suspension Specialists

# #1012RWBK - Installation Instructions

## for 10 & 12 Bolt Rear Axle Brake Kit

### Parts:

1 ea	Left Rotor	2 ea	Brake Hose
1 ea	Right Rotor	2 ea	Brake Hose Clip
1 ea	Left Caliper Assembly	2 ea	Hard Line
1 ea	Right Caliper Assembly	2 ea	10mm Banjo Bolt
1 ea	10 Bolt Gasket	4 ea	10mm Crush Washer
1 ea	12 Bolt Gasket	6 ea	3/8-16x 1-1/2 Gr8 Bolt
2 ea	Caliper Bracket	6 ea	3/8-16 Gr8 Nut
2 ea	Bracket Spacer	6 ea	3/8 Lock Washer
2 ea	Brake Hose Tab	12 ea	3/8 Flat Washer
2 ea	Brake Tab Clamp	10 ea	Wheel Stud

- Remove the hard lines from the axle. (New conversion hard lines are included with the disk brake kit.)
- Remove the rear drums from the axle.
- If you have the optional new parking brake cables or are not using a parking brake caliper, disconnect the rear portion of the cable from the front portion. If you are reusing your parking brake cables, disconnect them from the backing plate assemblies.
- Remove the rear axles and backing plates from the from the axle housing.
  - Chevrolet cars need to: Remove the differential gear cover. Remove the C-clips from the axles. Remove the axles. Remove the 4 bolts securing the backing plates to the housing. Remove the backing plate assemblies.
  - B.O.P. (Buick Oldsmobile, Pontiac) cars need to: Remove the 4 bolts securing the backing plates and bearing retainers to the housing. Remove the axles. Remove the backing plate assemblies.
- Check to see if the new wheel studs are longer than the wheel studs in the axle. If the new studs are longer install them into the axle.
- Install the axles and new brackets onto the axle housing. NOTE: The 1968-1969 Camaro / Fire Bird and 1968-1974 Nova / "X"-Body cars will have the right side bracket and caliper to the rear of the axle, and the left side will be to the front of the axle.
  - Chevrolet cars need to: Install the axles into the housing, Reinstall the C-clips on to the axle. Using the new gaskets, reinstall the differential cover. Using the new 3/8" hardware, attach the brackets and spacers to the axle flanges. The spacer will be against the inboard face of the axle flange (the side opposite the backing plate was on), and the bracket against the spacer.

### Replacement Parts:

1980-1985 Cadillac Seville Rear Calipers w/ Parking Brake  
1978-1983 Chevelle, Monte Carlo, Malibu, etc. Front Calipers  
CPP AR-8121E Rotors

### Notes:

This kit is designed to work with 15" or larger wheels.  
1968 & 1969 Camaro / Fire Bird and 1968-1974 Nova / "X"-Body use 2 right side calipers.

### Instructions:

- Disconnect the rear hard lines on the rear axle from the wheel cylinders.
- Disconnect the rear brake hose from the hard lines on the axle.

*Continued on next page*

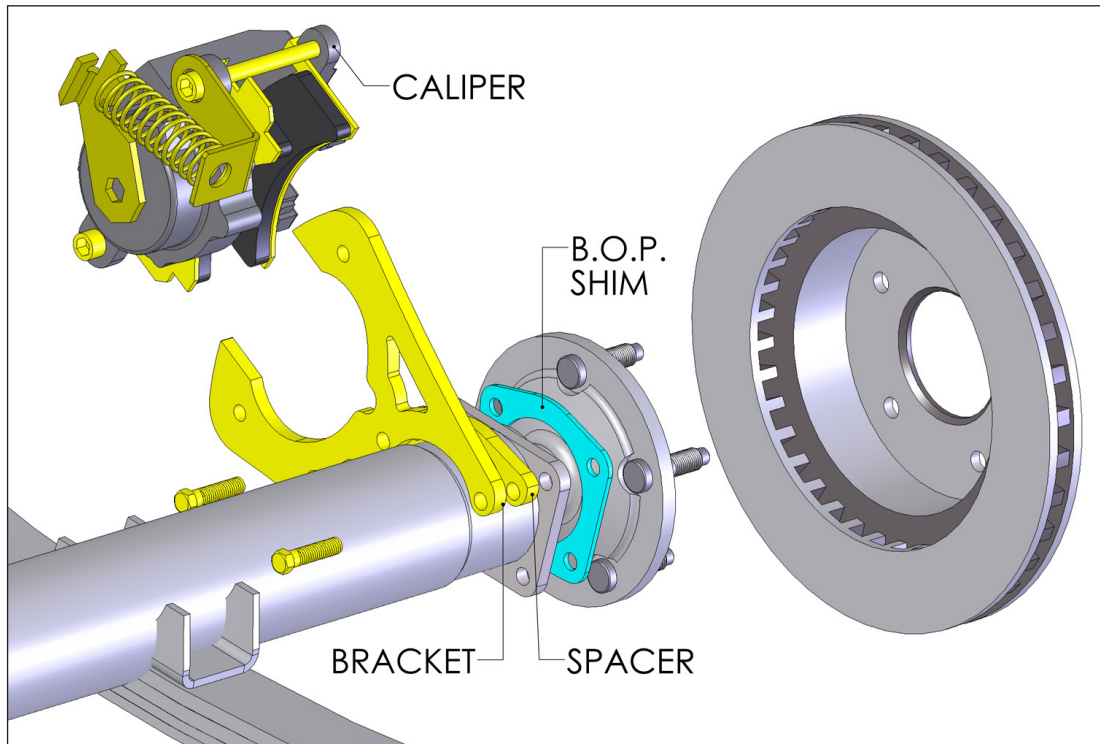



Steering, Brake & Suspension Specialists

# #1012RWBK - Installation Instructions

## (Continued)

- b. B.O.P. cars need to: Install the shim on the housing in same location the backing plate was. Install the axles, the bearing retainers should be against the new shims. Attach the brackets and spacers to the axle flanges. The spacer will be against the inboard face of the axle flange (the side opposite the new shim and bearing retainer), and the bracket against the spacer. Using the new 3/8" hardware bolt the brackets, spacers, shims, and bearing retainers to the axle flanges.
- 9. Install the rotors onto the axles.
- 10. Install the caliper assemblies onto the caliper brackets. The bleed screws will be toward the top of the calipers.
- 11. Check that the axles can turn freely.
- 12. If you are using parking brakes, install the parking brake cables.
- 13. Loosely install the new hoses onto the calipers. Do not tighten the bolts against the crush washers at this time.
- 14. Install the brake hose tabs and clips onto the new brake hoses.
- 15. Loosely connect the new axle hard lines to the brake hoses. The hard line may need to be repositioned. Secure the brake hose tabs to the axle with the tab clamp. If necessary, secure the hard lines to the axles with the appropriate clamps.
- 16. Tighten both ends of the brake hoses and hard lines.
- 17. If you are using parking brake calipers, you will need to adjust the calipers now. **WARNING:** These calipers will not work until the parking brake has been adjusted! The calipers will work their best when the adjustment is as tight as possible while allowing the rotor to be turned by hand.
- 18. Bleed the brakes.
- 19. Inspect the brake system for leaks!
- 20. Recheck that all the nuts and bolts are tight.

**PLEASE NOTE:** The installer needs to make sure that nothing can make contact with a brake hose, caliper, or other brake component at any point through the entire range of steering and suspension movement. The installer also needs make sure none of the steering or braking components can become bound or jammed at any time through the range of suspension or steering movement.

GENERAL TORQUE SPECIFICATIONS:					
1/4"	grade 5	10lb/ft	1/4"	grade 8	14lb/ft
5/16"	grade 5	19lb/ft	5/16"	grade 8	29lb/ft
3/8"	grade 5	33lb/ft	3/8"	grade 8	47lb/ft
7/16"	grade 5	54lb/ft	7/16"	grade 8	78lb/ft
1/2"	grade 5	78lb/ft	1/2"	grade 8	119lb/ft
9/16"	grade 5	114lb/ft	9/16"	grade 8	169lb/ft
5/8"	grade 5	154lb/ft	5/8"	grade 8	230lb/ft

**NOTE:** With 18" and larger wheels we recommend 1/2" wheel studs. The larger the wheel diameter, the greater the force is on the wheel studs. Please inquire about replacement wheel stud kits available from CPP.

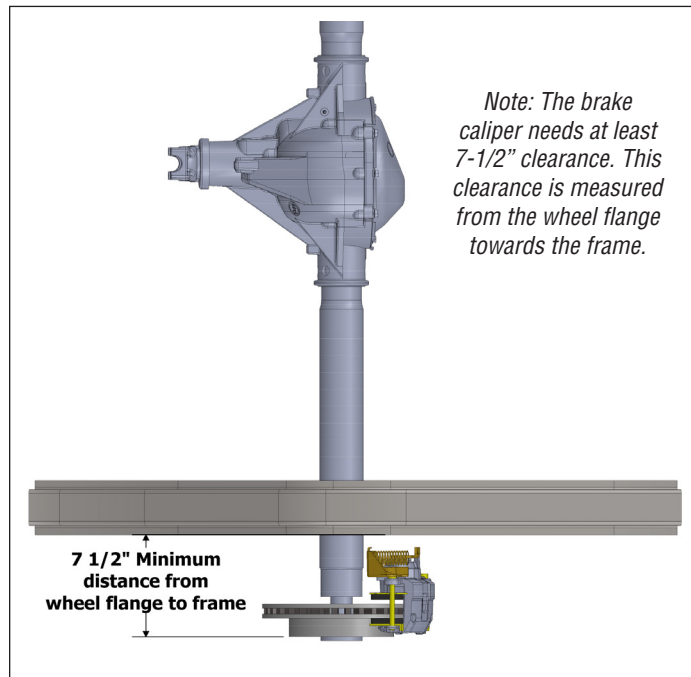

© Classic Performance Products, Inc. 2015  
All rights reserved. This document may not be reproduced without prior written permission of CPP.