



#CP934U - Sway Bar Installation Instructions

1" Rear Sway Bar for 1958-64 Fullsize

Hardware:

- 2 RH 400 U-bolts
- 2 RH 039 Plates
- 4 RH 102 Washers
- 4 RH 205 Bolts
- 10 RH 304 Lock-Nuts
- 2 RH 213 Bolts

Instructions:

1. Attach the sway bar to the reinforcing plates using the short bolts and U-bolts. The U-bolts may need to be bent slightly to fit the plates. This should be checked first for ease of assembly.
2. With plates attached to the bar, it should be held up under the car in position. The outer bend should be just forward of the shock absorber on the later models; on the older models the shock absorber is behind the axle; just be sure that the bar is just enough to the rear that it will not be struck by the tail pipe.

3. With the bar in position against the bottom of the lower suspension strut, mark it for drilling.

lower suspension strut, mark it for drilling.

4. Drill the strut with a 3/8" drill bit, and bolt the sway bar on. Dip should be down.
5. Have someone bounce the rear of the car while you check movement of all parts to be sure that no part of the kit can contact exhaust, shock, gas tank, differential, etc. If all is clear throughout maximum travel of the rear suspension, tighten all nuts.
6. Road test the car, and familiarize yourself with your car's greatly improved handling characteristics. As we cannot supervise your installation (or your driving), we cannot be held responsible for more than the cost of the kit.

BAR DETAIL MOUNT

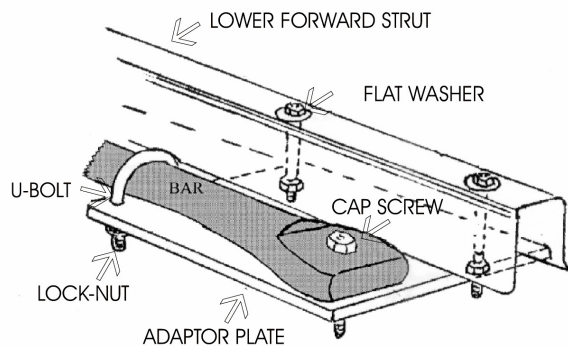

BAR ASSEMBLY ILLUSTRATION

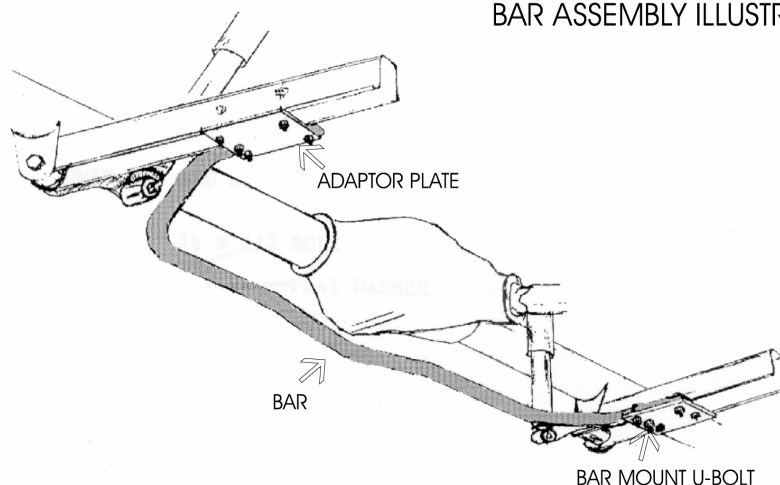

For technical help call Classic Performance Products Monday thru Friday 8:30am to 5:00pm at (714) 522-2000.

Classic Performance Products, Inc. 714.522.2000 | fax 714.522.2500
 175 E. Freedom Avenue | Anaheim, CA 92801 | www.classicperform.com